

TAB C-12

CAMPUS ACCESSIBILITY

GENERAL OVERVIEW

The University of Arizona (UA) is committed to a universally designed campus. While all institutions of higher education are legally obligated to comply with ADA accessibility standards, UA seeks to maximize access in the built environment to encourage the full and equitable participation of all users. We consider this a great opportunity to build rich diverse communities and contribute to a welcoming campus culture.

Universal Design enhances the viability of the built environment by creating sustainable facilities and outdoor spaces that are usable by all people to the greatest extent possible without the need for modification or adaptation. Designing inclusively will reduce the need for retrofitting or making individual accommodations.

Design Professionals should take into consideration the full range of human diversity with respect not only to disability, but to language, gender, age and other differences or characteristics. Such attention to diversity in the design process is integral to creating socially responsible built environments and will result in design features that facilitate social interaction, community, identity and belonging. Design choices starting from initial site planning to the choice of hardscape and hardware products effect usability and impact equitable design. When spaces are designed “universally,” individuals are no longer disabled by their environment, and can experience things in the same ways as others.

Seven general principles guide Universal Design:

- 1. Equitable use:** The design is useful and marketable to people with diverse abilities.
- 2. Flexibility in use:** The design accommodates a wide range of preferences and abilities.
- 3. Simple and intuitive:** Use of the design is easy to understand, regardless of the user’s experience, knowledge, language skill, or current concentration level.
- 4. Perceptible information:** The design communicates necessary information effectively to the user, regardless of ambient conditions or the user’s sensory abilities.
- 5. Tolerance for error:** The design minimizes hazards and the adverse consequences of accidental or unintended actions.
- 6. Low physical effort:** The design can be used efficiently and comfortably, and with a minimum of fatigue.
- 7. Size and space for approach and use:** Appropriate size and space is provided for approach, reach, manipulation and use, regardless of user’s body size, posture or mobility.

These design principles should inform the Design Professionals’ creative process from initial decisions regarding orientation of the building on the site and the layout of building amenities throughout the development of the design features, to the choices of products and furnishings.

To assist design professionals in applying Universal Design principles to projects at The University of Arizona, the University has developed specific standards – UA Accessibility Standards. **The UA Accessibility Standards are specific measurements, equipment and/or arrangements of accessibility compliance that the University feels provide a more universally accessible condition than the minimum requirements outlined in the ANSI/ADAAG standards.** These standards are also used as reminders for important conditions that are not different than the standards, but often overlooked in design documentation.

UA ACCESSIBILITY STANDARDS DESCRIPTION

The UA Accessibility Standards are organized to coordinate with ADAAG Standards. The types of construction projects have been organized into three groups.

New Construction	N
Renovations	R
Historic Renovations	H

Applicability of these standards is categorized as either **Mandatory (M)** or **Preferred (P)**.

TYPES OF PROJECTS

New Construction

New construction projects are defined as those projects involving the design and construction of new facilities and outdoor spaces where building and site development are unencumbered by pre-existing building or site accessibility constraints. Additions to existing buildings (inclusive of fully attached to minimally connected) are also considered to be New Construction Projects in regards to building accessibility, and, if provided with new entrances from the exterior, also in regards to site accessibility. Individual evaluation of additions to existing buildings should be undertaken early in the design process to outline the extent of existing building and/or site accessibility compliance that will be necessary.

Renovations

Renovation projects are defined as projects involving the renovation/alternation of a portion of an existing building that affects, or could affect, the usability. A renovation that could affect the usability of, or access to, an area of a facility that contains a primary function shall also include improvements to the path of travel to the renovated/remodeled area and the restrooms/drinking fountains serving that area so that they are readily accessible to, and usable by, individuals with disabilities, including individuals who use wheelchairs. These improvements shall be included to the maximum extent feasible, unless the cost and scope of such renovations exceed 20% of the cost of the renovation to the primary function area. Individual evaluation of whether or not such improvements are required should be undertaken early in the design process to outline the extent of existing building and/or site accessibility compliance that will be necessary. Please refer to 2010 ADA Standards Section 202.1-4.

Historic Renovations

Projects involving buildings/sites on the National Register of Historic Places must comply with the UA Accessibility Standards in such a way that impact is minimized and a building/site's historic integrity and character defining features are maintained. The determination of a building/site's historical integrity and character defining features shall be made by an individual meeting the Secretary of the Interior's Professional Qualification Standards for Historic Preservation.

Project Type Key
N = New Construction
R = Renovation
H = Historic Renovation
24 Pages

Applicability Key
M = Mandatory
P = Preferred

Due to the potential range of existing conditions, defining features and significant elements, and the ability of an historic renovation project to address such conditions, it is imperative that each project involving a qualified historic building or site undergo an evaluation early in the design process to outline the scope of accessibility compliance which can be achieved, and explore alternative design options or methods to provide programmatic access required of public entities. Please refer to ADA Standards Section 202.5.

COMPLIANCE REQUIREMENTS

All construction projects, new, renovation and historic renovation, must comply with accessibility requirements, including UA Accessibility Standards.

Accessibility codes, guidelines and standards with which the project shall comply are described in the Design Professional’s “Scope of Services” Exhibit to the agreement. (Consult with PD&C if this document is not available to you.) Additionally, there are UA Accessibility Standards that are more specific, restrictive and/or descriptive than the above referenced requirements. These are described in the following pages of this DSS tab. Project compliance expectations are included.

Compliance Requirements Key:

Mandatory M

Compliance with Mandatory UA Accessibility Standards is required.

Preferred P

Compliance with Preferred UA Accessibility Standards is encouraged, but to achieve accessibility as part of a renovation project the University recognizes there may be challenges such as:

- Conditions physically beyond the limits of the renovation or path of travel requirements.
- Spatial/structural/technical conditions which make accessibility infeasible to achieve.
- Conditions which cannot be addressed within a defined project scope or budget.

SECTION 1 - BUILDING BLOCKS

N R H Reach Ranges

N	R	H	Reach Ranges
M	M	M	Except as outlined in this section, the <u>operable portion</u> of building equipment and controls (such as electrical switches, fire alarm pull stations, above work surface telecommunications outlets, thermostats, automated external defibrillators (AED’s), fire extinguishers, etc.) shall be located 42” max. above the finished floor. Note: All elevator call buttons shall be located 48" max above finished floor For information on reach ranges for equipment in rest rooms, toilet rooms, and bathing rooms, see SECTION 4 - PLUMBING ELEMENTS AND FACILITIES.
M	M	M	Where devices have more than one operable mechanism, and are more than 6” apart (such as a tall, rectangular shaped fire extinguisher cabinet), a maximum height of 48” is allowed for the higher mechanism to allow the cabinet to be mounted on the wall at a desirable height above finished floor. Consult with DRC.

Project Type Key
 N = New Construction
 R = Renovation
 H = Historic Renovation
 24 Pages

Applicability Key
 M = Mandatory
 P = Preferred

M	M	M	Door access card reader keypads shall be centered at 42 inches above finished floor. When a pedestal is used at entrances, use a UA specific ADO/keyless access pedestal. Button location/pedestal shall be centered in the level 30"x48" clear floor space for side approach.
M	M	M	Control plates for automatic door openers shall be centered at 33" above the adjacent finished surface and centered in the 30" x 48" clear floor space. For wall mounted locations, reference Tab C-12 Typical ADO locations diagrams TAB C12-D1 thru C12-D6.

SECTION 2 – ACCESSIBLE ROUTES

N R H During Construction

M	M	M	Renovations that temporarily eliminate building-wide access features (i.e. change of building entrance, access through building, accessible restrooms, elevators, etc.) shall provide comparable, temporary replacements, including automatic door openers (ADO's) and temporary directional signage, for said features. Temporary directional signage placement and wording to be reviewed by DRC.
M	M	M	Construction fencing/staging, earthwork and temporary drainage conditions shall be designed to maintain existing accessible routes or alternative, temporary accessible routes, and directional signage shall be provided.
M	M	P	Temporary ramps used during construction shall have ADA compliant handrails, landings and edge protection, and shall attempt to achieve a maximum slope of 1:16.

N R H Accessible Path of Travel - Exterior

M	M	M	Minimum sidewalk width shall be 6' (72"); wider as required on major routes.
M	M	M	Connect to an accessible campus route at all pedestrian access points to parking structures and other parking facilities.

N R H Surface Materials

M	M	M	<p>Decorative ground surface treatments (i.e. exposed aggregate concrete, unit pavers, stone paving, etc.) shall provide a surface free of horizontal gaps or vertical transitions in excess of 1/2" inch.</p> <ul style="list-style-type: none"> • Provide adequate sealant at expansion joints to minimize level change • Minimize expansion joints that are not perpendicular to the path of travel. • Other than joint between building slab and paving, avoid expansion and control joints at maneuvering areas in front of doors • Limit aggregate size in exposed aggregate concrete to 1/4" maximum • Pavers shall not be used on ramps. Provide pavers with straight edge (no bevel) in walking surfaces <p>NOTE: Decorative larger aggregate and stonework can be used in areas that are not walking surfaces.</p>
---	---	---	---

M	M	M	Granular surface materials used to create exterior paths of travel shall include a stabilizer to provide a surface that is usable during all weather conditions. Granular surface materials may not be used on path of travel surfaces with a slope steeper than 1:20 or in areas planned for furniture.
M	M	M	Changes in surface material, both inside and exterior, shall be provided with a compliant, durable transition that will meet the change in elevation height requirement throughout the life of the building/space.
M	M	M	See "Curb Ramps" for information on detectable warning surfaces.

N R H Accessible Routes - Interior

M	M	M	Maintain 42-48" clear aisles in retail spaces, at open office workstation aisles and in public spaces with movable furniture. Maintain ADA compliant clear path of travel in areas with movable furniture.
M	M	M	Coordinate transitions between varying floor finishes. For renovations where it is not possible to provide ½ inch transitions, a threshold ramp is required. An associated ADO is required at doors with threshold ramps.

N R H Queueing

M	M	M	Provide clearances and turning radii in compliance with ADA accessible route requirements for all temporary and permanent line stanchions. Stanchion bases cannot reduce the clear width of the queue to less than 32".
---	---	---	---

N R H Bicycle Parking Adjacent to Accessible Routes

M	M	M	Locate bicycle parking racks so that parked bicycles do not encroach in the accessible path of travel (POT). Allow for bicycles parked with front wheel secured to hoop. Install bicycle rack 24" from POT if parallel, and 48" from POT if perpendicular. Parallel installation is preferred.
---	---	---	--

N R H Building Entrances

M	P	P	The main entrance of a building shall be universally accessible via a single route. Coordinate site elevations and grades to ensure universal access. NOTE: Some buildings might have more than one main entrance.
M	P	P	All building entrances shall be universally accessible, including "employee" entrances, or entrances other than the "main" entrance.

N R H Doors and Doorways and Glazing

M	M	M	Kick-plates shall be provided on non-latching doors with push-pull hardware.
---	---	---	--

M	M	M	<p>Frameless Glass Doors – Detail to provide for the following:</p> <ul style="list-style-type: none"> Decorative contrast at latch-side edge of the door, and on adjacent edge of glass wall or panel An automatic door operator. For banks of frameless glass doors, an automatic door operator will be required at only one door <p>When a floor pivot is used, the required clear width shall be provided when door is in any position. This may require a wider door.</p> <p>Provide a door stop when it is necessary to prevent the door from opening past 90 degrees.</p>
M	M	M	All latching door hardware must be operable with a closed fist.
M	M	M	Doors shall not exceed 5 lb. max. opening force. This is applicable at both interior and exterior doors unless an ADO is provided. Consider this requirement when planning oversized doors.
M	M	M	Door hardware must be usable at standard door handle height (38” – 42”).
M	M	M	<p>The following door types shall not be used:</p> <ul style="list-style-type: none"> Revolving doors Sliding glass doors with a bottom track (occurring on an accessible route) Pocket doors Barn doors Center-pivot doors
M	M	M	Provide information on non-standard door pulls for review and approval prior to inclusion in contract documents. Example: Pulls that extend into lower 34” of door on the push side, which can cause problems for wheelchair users.
M	M	M	At glass wall sections that go to the floor provide a decorative contrast or gradient treatment somewhere within 36” and 48” above finished floor to make it easier for the visually impaired to discern the difference between a plane of glass and an opening. This applies to sliding glass door sections as well.

N R H Automatic Door Operators

M	M	M	<p>Automatic door openers shall be installed at each main entrance to a building. Take special care at courtyard buildings with multiple exterior doors so that all building areas can be accessed by a door with an ADO (this applies at all building levels).</p> <p>See DSS 08720 for ADO product information.</p> <p>See DSS TAB C-6 for bollard mounted installation.</p> <p>In courtyard buildings, ADO’s may be necessary at other essential exterior doors such as classrooms and restrooms. Consult with PD&C PM and DRC.</p>
M	M	M	Electrical infrastructure for automatic door operators shall be provided at all alternate accessible building entries.

M	M	M	Design Professional shall clearly note ADO control locations on Design Development and Construction Document architectural floor plans for review by PD&C Project Manager, DRC and for coordination with Amer-X keyless access interface. <ul style="list-style-type: none"> • Locate ADO's per Figure 1. For guidance on location of Automatic Door Operators, refer to diagrams C12-D1 through C12-D6. • Refer to Section 1 – Building Blocks, Reach Ranges for mounting height of control plate.
M	M	M	Use the UA specific pedestal for ADO button and keyless access equipment where an exterior wall location is not available.
M	M	M	Make provisions for incorporating Automatic Door Operator in design of door head frame.

N R H Ramps

M	M	P	Where changes in elevation are encountered (including courtyards and open spaces), provide a universally accessible design that addresses the elevation change, rather than providing separate stairs and ramp.
M	M	M	Where space and grades allow, sloped sidewalks (slope 1:20 or flatter) shall be used in lieu of ramps to overcome changes in elevation.
M	P	P	When used, ramps (defined as anything steeper than a 1:20 slope) shall have a maximum 1:16 slope.
M	M	M	No curvilinear ramps except where space and grades allow for an interior radius greater than 30ft. Ensure compliant slopes at all parts of the ramp in all directions.
M	M	M	No pavers, stabilized granular surfaces, or any other surface that will become inconsistent over time.

N R H Curb Ramps

M	M	M	Curb ramp slopes shall be 1:12 maximum. Flares may be 1:10 where there is a clear landing at the top of the ramp.
M	M	M	Concrete aprons shall be provided at the bottom of curb ramps. Minimum 3ft. level landing is required at the top of the ramp.
M	M	M	Curb ramps within sidewalks (parallel to the path of travel) shall be provided with a 1:16 slope.
M	M	M	The University's standard for detectable warning surface is TekWay Dome-Tiles manufactured by StrongGo LLC (Phone 520-547-3510, Fax 520-547-3515, Web stronggo.com) or equal . The standard color is Terracotta. The depth of detectable warning surface in the direction of travel shall not exceed 24".

			<p>Detectable warnings are required for pedestrian routes</p> <ul style="list-style-type: none"> • At streets where they cross vehicle traffic • At transportation platform boarding edges <p>NOTE: Excludes routes within parking lots</p>
--	--	--	---

N R H Elevators and Lifts (see also DSS Section 14000)

M	M	M	Platform lifts shall not be used.
---	---	---	-----------------------------------

SECTION 3 – GENERAL SITE AND BUILDING ELEMENTS

N R H Parking Spaces

M	M	M	<p>Van accessible parking spaces are preferred, typical and shall be a Universal size of 8'-6" wide parking space with a 8'-6" wide access aisle. Standard 18'-0" depth. The 8'-6" wide access aisle can be shared between two spaces.</p> <ul style="list-style-type: none"> • Sidewalks leading to or from parking shall be 6 feet wide minimum. Provide a bollard with an integral signpost with the ADA parking sign centered within each parking space. (No wheel stops.) The bollard may not encroach into the minimum clear sidewalk area. <p>Reference TAB C-12 ADA Parking Sign and Post Diagram</p>
---	---	---	---

SECTION 4 - PLUMBING ELEMENTS AND FACILITIES

N R H General

M	M	M	Vestibule (i.e. doors in series) entries into rest rooms are not permitted.
M	P	P	All gender restrooms shall be accessible for the purposes of privacy and/or assisted use. To maximize visibility, locate all gender restrooms in the same area of the building as gendered restroom blocks (multi-stall restrooms). In renovations where restrooms are not in the same area, provide wayfinding directional signage at the gendered restrooms.
M	P	P	Accessible all gender rest room(s) shall not be used as a substitute for providing accessibility to multi-stall rest rooms (exception: renovations where toilet fixture count prohibits removing any fixtures).

N R H Toilet and Bathing Rooms

M	M	P	Single occupant public/employee restrooms shall be fully accessible.
M	M	M	Provide accessible hand-held shower system that allows height adjustment with a closed fist. Use models that do not require grasping or twisting. No knobs.

M	M	P	Private toilet rooms for employees, i.e., only accessed through a private office, shall be designed to allow accessible toilet room requirements to be added in the future. Approach, entry, and exit shall be fully accessible. Provide 5' turning radius within room. Provide blocking for future grab bar installation.
---	---	---	--

N R H Water Closets and Toilet Compartments

M	M	P	A side approach toilet shall be provided. Where possible, provide an "end stall design" where it is possible to have a 5' turning radius located completely within the compartment. Where a restroom has more than 1 wheelchair accessible stall, provide 1 for left side approach and 1 for right side approach. NOTE For renovations where the toilet is centered more than 18" away from the wall, furring out the wall is an approved solution. Accessories placement and the minimum floor space requirements shall comply.
M	M	M	Provide vertical grab bar at water closets in wheelchair accessible, accessible ambulatory stalls and accessible single use bathrooms/restrooms. 18" minimum in length, shall be mounted with the bottom located 39"-41" AFF, and 39" to 41" from the rear wall.
M	M	M	When Ambulatory stalls are provided, specify an accessible height water closet, 17"-19" to top of seat. Ambulatory stall width: 35" to 37" interior dimension measured to the partition/walls. Center the toilet in the stall. All other toilet accessories and installation heights are the same as those required for accessible toilet rooms / stalls.
M	M	M	Flush valves for toilets shall be located at the open approach side of the toilet. NOTE: Where <u>existing</u> toilet seat height is a minimum 14.5" AFF, the Big John Toilet Seat company is an approved solution to raise the seat height to comply.

M	M	M	Toilet Paper Dispensers shall be surface mount, UA standard (OFCl) continuous feed compact side by side double roll type (10Wx6Dx7H) and shall be located so that: <ul style="list-style-type: none"> the centerline of the dispenser is located 7" from the front edge of the toilet bowl. there is 2 inches clear space below the grab bar to the top of dispenser. <p>Reference TAB C-12 Accessible Toilets/Ambulatory Stalls- <u>Additional Information</u> and Toilet Room Elevation Diagrams</p> <p>NOTE: Quad / Four Roll dispenser types or jumbo single roll types, are NOT allowed in wheelchair accessible stalls, ambulatory stalls or accessible single occupant / all gender toilet rooms.</p>
M	M	M	Sanitary Napkin Disposal Types are project specific; confirm with PD&C PM. Free-standing box type shall be UA standard (OFOI). Surface mounted type shall be Bobrick B270 (CFCl) . <ul style="list-style-type: none"> When installing surface mounted units in accessible stalls, ambulatory stalls and single occupant / all gender toilet rooms, locate surface mounted units toward the

			back of stall, next to toilet paper dispenser with 4- inches clear space below the grab bar and the top of disposal.
M	M	M	Seat cover dispensers: When installed in accessible stalls, locate surface mounted units (CFCI) on the toilet wall, 2 inches below the grab bar with the outside edge of dispenser aligned with the end of the grab bar.
M	M	M	Door pulls shall be provided on both sides of doors to accessible and ambulatory toilet compartments. Outward swinging stall doors require 2 additional pulls on the interior side of door. Pulls must be operable with a closed fist and mounted horizontally; 5" minimum wide opening, with 1 ¼" clearance . Install pulls at 36" AFF and 8 inches away from the edge of the door for symmetrical placement.
M	M	M	Provide a coat hook at 42" max above the floor in the accessible and ambulatory toilet compartment. Locate in the center of the door (and not above the latch) or locate on a side wall or partition in end of row stalls, away from the side grab bar so hanging items will not conflict with grab bar clearance.
M	M	M	Latching mechanism for accessible toilet compartment doors shall be operable with a closed fist. Large paddle type preferred.
M	P	P	Provide full length framed mirror (CFCI) in multi-stall restrooms and accessible single occupant / all gender toilet rooms. Consider best wall location for viewing and to avoid sight lines into the room. <ul style="list-style-type: none"> • Top edge of mirror shall be mounted at a minimum of 74" above finished floor, with reflective surface 20 inches maximum above finished floor.

N R H Lavatories and Sinks

M	M	M	Provide 36" width minimum per lav, and position lavs so that soap and paper towel dispensers can be installed on side return walls without overlapping the required clear floor space at the sink. Request product cutsheets from PD&C Project Manager to coordinate (OFCI) dispenser dimensions/ depth.
M	M	M	Soap dispensers (OFCI) shall be UA standard surface mounted and shall be operable with one hand. Align dispenser with the top of backsplash or with the sink splash/bottom edge of mirror at wall hung sinks to maintain 4 inches clear space beneath for access. Provide min. (1) dispenser on wall where there is a side wall adjacent to sink. Locate the dispenser above the counter area , with operable mechanism at 42" max. above the finished floor and at 6 inches away from the front edge of counter. Under counter mounted soap dispensers and pump type dispensers are not allowable unless motion operated.
M	M	M	Provide Mirrors above lavs and sinks. <ul style="list-style-type: none"> • Bottom edge of <u>reflective surface</u> at 40" max AFF. Account for the mirror frame and/or etching when locating mirror. • Slanted/angled mirrors are not permitted.

Project Type Key
N = New Construction
R = Renovation
H = Historic Renovation
24 Pages

Applicability Key
M = Mandatory
P = Preferred

M	M	M	A 27" knee clearance shall be provided under accessible wall hung sinks and countertop sinks. "Extended" wall hung sinks (those with a deep front-to-back dimension) shall not be used to achieve the 27" knee clearance. For design of built-in countertop vanities and vanities with angled access panel sink shrouds. Reference TAB C-12 <u>Angled Access Panel Shroud (at Sink) Diagram.</u>
M	M	M	Sink faucets shall be automatic, wrist blade, lever-operated, or "push-on" type with delayed shut off to permit single hand operation.
M	M	M	Adaptable sinks with accessible cabinetry (such as sinks found in employee kitchen areas, laboratories, dwelling units, etc.) shall be provided with a finished flooring surface in the under-cabinet space. The cabinet doors shall be provided with 180-degree hinges to allow the doors to swing back against the cabinet face. A 27" H knee clearance shall be provided at the open area below the countertop apron at adaptable sink areas without cabinet doors.
M	M	M	Paper towel dispensers (OFCI) shall be UA Standard surface mount and located so that operating mechanism is 42" max. above the finished floor. Dispensers may not overlap clear floor space at sinks or create a non-cane detectable protrusion along the path of travel.
M	M	M	Hand dryers with bottom air outlet shall be located so that operating mechanism is at 40" above the finished floor. Hand dryers that hands are inserted into, shall be located so that top of unit is 36" above the finished floor.
M	M	M	Trash receptacles shall be UA standard types. (OFOI). Indicate receptacle locations to ensure trash cans do not impede maneuverable clearance areas at doors. Maintain clear floor space requirements. Under-counter trash receptacles with a countertop cutout are acceptable if clear floor space is maintained

N R H Baby Changing Stations

-	-	-	Project specific; confirm with PD&C PM and DRC. When required, baby changing tables shall be located in main public restroom blocks and accessible single occupant / all gender toilet rooms. Install so that at the open and lowered position, surface is 34" above the floor. In the closed position, the station cannot overlap required floor spaces at fixtures or maneuvering clearances. Stations are not permitted within a water closet stall but can be located in single toilet rooms if maneuvering clearance space is maintained.
---	---	---	--

N R H Adult Changing Stations

-	-	-	Project specific; confirm with PD&C PM and DRC. When required, Adult changing tables shall be located in accessible single occupant / all gender toilet rooms. Install manually operated station so that at the open and lowered position, surface is 22" above finished floor.
---	---	---	---

N R H Shower Compartments

M	M	M	<p>In non-residential conditions, accessible showers shall:</p> <ul style="list-style-type: none"> • be a 36"x36" transfer-type entry with a padded, fold down bench (with integral support legs) that extends to within 3 inches of the opening of the stall and is located on the wall opposite the controls/shower head. • have grab bars installed in compliance with ANSI requirements. • have an accessible hand-held shower system that allows height adjustment with a closed fist and that do not require grasping or twisting. No Knobs. <p>For transfer type shower ½" high threshold is allowable; beveled, rounded or vertical.</p> <p>In existing buildings where a ½" high threshold would disturb structural reinforcement of the floor slab, a 2" high threshold is allowable.</p> <p>Shower curtain can encroach on 36" shower dimension to allow it to be located on the inside of the threshold. Allow 3" maximum from edge of bench to curtain.</p> <p>Locate fire alarm device(s) in bathrooms so that it is visible from all locations within room. Take particular care in locating device so that it can be seen from inside shower stalls (for hearing impaired). If general room device cannot be seen from inside a shower, provide a visual fire alarm device in shower drying area.</p> <p>See Section 8 - Dwelling Units for requirements on shower compartments in residential conditions.</p>
---	---	---	---

SECTION 5 – COMMUNICATION ELEMENTS AND FEATURES

N R H Assisted Listening Systems

M	M	M	<p>Assisted listening system are required where amplification is provided. Consult with the PD&C PM and DRC on the appropriate type of system for the building/space. Preference is to use an audio to network bridge system for mobile devised for public spaces. Consult with DRC to ensure appropriate signage is added to the signage package for the space.</p> <p>The new approach is to use a system that requires only a box in the room: https://en-us.sennheiser.com/mobileconnect-smartphone-hearing-system-app</p> <p>This system connects to mobile devises, although some receivers are required to be provided with the system. Ticketing counters, information centers, teller booths, and other locations where a transaction is across or through a physical barrier such as glass shall include looping. Consult with PD&C PM and DRC.</p>
---	---	---	--

N R H Emergency "Blue Light" Phones

M	M	M	<p>Access shall be provided to Emergency "Blue Light" Phones. Specifically, the following shall be provided (see also Diagram C12-D7):</p> <ul style="list-style-type: none"> • Accessible approach, with access from multiple directions • Provide 30" x 48" accessible clear ground space in front of the operable portion of the phone. Install unit at grade, not on a pad or in a median, to maintain operable mechanisms within allowable reach range. Provide Site Plan detail, include orientation.
---	---	---	---

N R H Signage

M	M	M	For any signage, interior or exterior, that is not being fabricated by the UA sign shop, DRC shall review and approve.
M	M	M	The updated International Access Symbol found at www.accessibleicon.org is to be used wherever access is designated.
M	M	M	DRC shall review all signage verbiage. For example, UA does not include the word 'handicap' on any signage.
M	P	P	Monument signage at buildings with multiple entrances shall be coordinated with the overall building directional/wayfinding signage locations and reviewed by DRC.

SECTION 6 – SPECIAL ROOMS AND SPACES

N R H Auditorium, Tiered Classrooms, and Assembly Areas

M	P	P	<p>In auditoriums, tiered classrooms, conference rooms and assembly areas, wheelchair accessible seating and companion seats shall be provided for a variety of universally accessible seating locations wherever possible to facilitate inclusion for disabled students and guests.</p> <ul style="list-style-type: none"> • Companion seating shall be designated only in assembly areas where ticketed events are held or where seating is often reserved.
P	P	P	Sloped classrooms preferred (not tiered or stepped) unless access can be provided to intermediate level(s).
M	P	P	<p>Per ADA Guidelines, locate companion seats to provide shoulder to shoulder alignment (front to back) with adjacent wheelchair space, which is measured to be 36" from the front of the wheelchair space.</p> <ul style="list-style-type: none"> • For WC spaces that allow front approach, a 36"x48" clear floor space is required. • For WC spaces that allow only side approach, a 33"x60" clear floor space is required. • For all WC spaces, 17" of the clear floor space may extend under a desk or table surface, where applicable.
M	P	P	Wheelchair access shall be incorporated in the primary access route to the stage/teaching station areas.

Project Type Key
 N = New Construction
 R = Renovation
 H = Historic Renovation
 24 Pages

Applicability Key
 M = Mandatory
 P = Preferred

M	P	P	In fixed seating situations, aisle seats with fold up arms for use by disabled shall be provided and identified.
M	M	P	When fixed seating is provided with tablet arms, consult with PD&C Project Manager and DRC for accessible equivalent seating alternatives. A table area, or areas with movable seating may be required. <ul style="list-style-type: none"> extended accessible table surfaces dispersed in multiple locations preferred, to facilitate universal access and inclusion.

N R H Dressing, Fitting and Locker Rooms

M	P	P	Where changing clothes is essential to the space, at least one changing surface that measures a minimum of 33"x60" is required in each gendered area, or one in an all gender area.
---	---	---	---

N R H Kitchens and Kitchenettes

M	M	P	Employee kitchens and break rooms must be accessible. Provide work surface 34" above finished floor and an accessible sink with accessible cabinetry, angled access panel or open space below the sink. Finished flooring surface shall be provided in the under-cabinet space. Provide 180-degree hinges to allow cabinet doors to swing back against the cabinet face. <ul style="list-style-type: none"> 27" H knee clearance shall be provided at the open area below the countertop apron at sink areas without cabinet doors. Clearance at angled access panel shroud; 8" min. D measured from face of apron to the top of angled panel and 11" min. D measured from face of apron to the bottom edge of angled panel. Bottom of panel 9" min. AFF. Reference TAB C-12 Angled Access Panel Shroud (at Sink) Diagram. A shallow storage shelf under the open cabinet space is permitted. Locate 9" min. AFF and maintain 11" min. D knee space to front edge of shelf. Above counter Microwaves with controls above 42" are not permitted unless a second countertop microwave is provided. Refrigerator "side by side" door style preferred.
---	---	---	--

N R H Academic Laboratories

M	M	M	Academic (teaching) laboratories shall be accessible. Provide accommodations at 5% of work stations (minimum of 1 station) per lab. The accessible work station(s) shall provide, or have the capacity to provide, those elements of laboratory furnishings and equipment specific to the type of teaching expected to be conducted in the laboratory. Use of adjustable modular lab furnishings provide the best adaptability for users of all heights, and for those who use wheelchairs.
M	M	M	Accessible work stations shall include: <ul style="list-style-type: none"> a bench space, either adjustable in height or a maximum of 32" high at the work station, and 34" high at a sink, with 29" minimum clearance below access to an ADA compliant sink with single action lever controls or wrist blade handles faucet controls

			<ul style="list-style-type: none"> lab gases and power outlets located on the side of the bench or within 18" of the front edge of the bench with single action lever controls or wrist blade handles storage facilities (for lab equipment/materials to be utilized by students in the lab) within ADA reach ranges
M	M	M	Where academic laboratories utilize fume hoods, provide 5% of total, or at least one, accessible fume hood with: <ul style="list-style-type: none"> a 32" high (maximum) work surface with 29" clearance below gas/services within the hood located on the side of the hood or within 18" of the front edge of the hood, with single action lever controls or wrist blade handles
M	M	M	Eyewashes / safety showers shall be independently accessible and operable by a wheelchair user.
M	M	M	Where non-laboratory teaching amenities (writing surfaces, lecture areas, etc.) are provided within academic laboratories, 5%, or at least one, shall be accessible.
M	M	M	Specific purpose teaching facilities (such as tissue culture rooms) shall provide a wheelchair accessible space with: <ul style="list-style-type: none"> a 5' diameter turning radius within the room a bench space 2'-6" long with a 32" height (maximum) and a minimum 29" clear space below (for a depth of 9" plus toe space beyond)

N R H Research Laboratories

M	P	P	Research laboratories shall have provisions for wheelchair accessibility. The accessible work station(s) shall provide, or have the capacity to provide, those elements of laboratory furnishings and equipment specific to the type of research expected to be conducted in the laboratory. Use of adjustable modular lab furnishings provide the best adaptability for users of all heights and those who use wheelchairs.
M	P	P	Individual research laboratory rooms assigned to specific employees are considered employee work areas. For employee work areas, basic access is required for approach, entry, and exit.
M	M	P	Research laboratory rooms with open assignment workstations/bench space shall be provided with 5% of total, or at least one accessible workstation with: <ul style="list-style-type: none"> a bench space, either adjustable in height or a maximum of 32" high at work station and 34" high at sink, with 29" minimum clearance below an accessible sink with faucet controls located on the side (not rear) with single action lever control or wrist blade handles faucet controls lab gases and power outlets located on the side of the bench or within 18" of the front edge of the bench with single action lever controls or wrist blade handles aisles 42"-48" wide for accessible bench space/hoods storage facilities within ADA reach ranges

M	M	P	Shared, specific purpose research laboratory rooms (such as tissue culture rooms) in open assignment research laboratories shall have at least one wheelchair accessible workstation/hood with: <ul style="list-style-type: none"> • a 5' diameter turning radius within the room • A bench space 2'-6" long by 32" high (maximum), and a minimum 29" clear space below
M	M	P	For shared fume hoods in open assignment research laboratories, provide 5%, or least one accessible fume hood(s) with: <ul style="list-style-type: none"> • a 32" high (maximum) work surface and a minimum 29" clearance below • gas/services within the hood located on the side of the hood or within 18" of the front edge of the hood, with single action lever controls or wrist blade handles

SECTION 7 –FURNISHINGS AND EQUIPMENT

N R H General

M	M	M	When loose furniture may be moved into the path of travel, 42" - 48" aisles for clearance / maneuvering shall be provided.
---	---	---	--

N R H Seating at Tables, Counters, Dining and Work Surfaces

M	M	M	A minimum of 5% of work/dining surfaces (computer tables, dining tables, study carrels, etc.) used for extended periods of time by transient populations shall be accessible. Surfaces shall be a maximum of 32" above finished floor to the top, and provide a minimum clear height of 28" below the surface. The clear height shall extend a minimum of 9" back from front edge of the surface with a vertical clearance wheelchair footrests beyond. <ul style="list-style-type: none"> • 50% of Dining surfaces shall be universally accessible. • Classroom furniture shall be universally accessible with a minimum clear height of 28" below the surface wherever possible. A minimum of 5% shall be height adjustable whether it is mechanical, manual, or by adding casters.
M	M	M	Accessible height service / reception counters shall be provided at the primary queuing point or staffing location to maintain universal eye to eye contact. Worksurfaces / counter heights shall be a maximum of 34" above finished floor with min. 28" H knee clearance and accessible storage. <ul style="list-style-type: none"> • Worksurfaces must be accessible from both the staff sides and visitor sides. • Shrouds that conceal computer monitor(s) from visitor's view is acceptable. Consult with DRC.
M	M	M	Food Service Counter surfaces shall be a maximum of 34" above finished floor, except in situations where a lower counter is needed to ensure items on the countertop allow for operable mechanisms at 42" AFF. <ul style="list-style-type: none"> • All dispensers must be mounted so that all operable mechanisms and dispensing locations are no higher than 42" AFF. • Tray slide surfaces shall be 28" max AFF.

Project Type Key
N = New Construction
R = Renovation
H = Historic Renovation
24 Pages

Applicability Key
M = Mandatory
P = Preferred

M	M	M	Audio Visual Technology, Screens, Monitors and Graphics / Artwork
			<p>Mounting heights are required to meet the same criteria as other objects within paths of travel and may not create a non-cane detectable protrusion (may not protrude more than 4 inches from the wall surface when mounted between 27 inches and 80 inches from the floor). If an object protrudes more than 4 inches from wall, provide a cane detection warning, such as:</p> <ul style="list-style-type: none"> • Placing a narrow cabinet or similar item below the object; providing a recessed niche to inset the object at the required depth; or framing a “pop out” (required depth x 27” AFF) at the lower section of wall below the object. • All switch/controls or operable mechanisms shall be installed at 42” AFF.

SECTION 8 – DWELLING UNITS

N R H General

M	P	P	<p>Residence Halls shall be designed to provide students with disabilities a choice of room types and amenities dispersed throughout the building and comparable to that of non-disabled students.</p> <p>The locations of wheelchair accessible rooms within residence halls shall be:</p> <ul style="list-style-type: none"> • on a convenient path of travel from the main entrance and elevator • close to building-wide amenities/services (i.e. kitchen, laundry, study/common rooms, etc.)
M	P	P	<p>Common areas and amenities in Residence Halls shall be universally designed regardless of whether living quarters are accessible or not.</p> <p>Rooms with access features should be identified early in the design development phase and shall be coordinated with vertical access and circulation routes.</p>
M	M	P	<p>Locate fire alarm device(s) in shower rooms or restrooms with multiple stalls so that it is visible from all locations within the room. Take particular care in locating a device so that it can be seen from inside shower stalls (for hearing impaired). If general room device cannot be seen from inside a shower, provide a visual fire alarm device in shower drying area.</p>
M	M	P	<p>Provide accessible student rooms that have accommodations for both wheelchair users and the hearing impaired. Also provide accommodations for the hearing impaired in a portion of the non-wheelchair accessible student rooms.</p>

N R H Entrances

M	P	P	<p>Some residence halls will have student rooms accessed by proximity card readers. At these halls, all accessible building entries shall also be provided with proximity card readers, as well as automatic door operators.</p>
---	---	---	--

M	P	P	All other accessible building entries to residence halls shall be provided with automatic door operators.
M	M	M	Accessible rooms with mobility features shall be equipped with an ADO and either a proximity card reader or remote. ADO control mounted in room interior only.

N R H Paths of Travel

M	P	P	Stairs and elevators shall be located on a common route within the building as close together as possible.
M	M	M	Interior doors along the path of travel to wheelchair accessible rooms and those to building wide amenities/services (i.e. kitchen, laundry, study/common rooms, etc.) shall be provided with automatic door operators.

N R H Doors

M	P	P	Wheelchair accessible rooms on all floors of a residence hall shall be provided with the infrastructure for automatic door operators. Some wheelchair accessible rooms shall also be provided a with proximity card reader. Review quantity and location required with PD&C PM and DRC.
M	M	P	In residence halls that have student rooms accessed by proximity card readers, all doors on the path of travel to those rooms shall also be provided with a proximity card reader, as well as with an automatic door operator.
M	M	P	If “peep holes” are provided to resident rooms, provide an additional “peep hole” at 48” above finished floor in the doors of wheelchair accessible rooms.
M	M	M	Infrastructure for door knock signalers (i.e. strobes) shall be provided for the entry doors to hearing impaired accessible rooms. Provide alert signaler in all interior rooms within the suite.

N R H Bathrooms

M	M	M	<p>Shower compartments in residential accessible bathrooms shall be 30” x 60” roll-in and have:</p> <ul style="list-style-type: none"> • a padded, fold down bench with integral support legs installed on the wall adjacent to the controls/shower head • the shower head and controls located on back wall of shower, adjacent to the seat wall <p>A ½” high threshold is allowable; bevel to maintain compliance with ADAAG change in level requirements.</p> <p>NOTE: Rear trench drains and rollover dams or removable thresholds are allowed for water control.</p>
M	M	M	Shower curtain can encroach on 30” shower dimension to allow it to be located on the inside of the threshold. Allow 3” maximum from edge of bench to curtain.

Project Type Key
N = New Construction
R = Renovation
H = Historic Renovation
24 Pages

Applicability Key
M = Mandatory
P = Preferred

M	M	M	Accessible lavatories in residential accessible bathrooms shall be provided with counter space (to accommodate personal care items).
---	---	---	--

N R H Closets

M	M	M	Provide adjustable height closet rods and shelves in accessible apartments and student rooms in residence halls. 50% of storage shall be at accessible height.
---	---	---	--

N R H Windows/Window Coverings

M	M	M	All operable window mechanisms to open/close window(s) in wheelchair accessible rooms shall be within accessible reach ranges.
M	M	M	Operators for window coverings in wheelchair accessible rooms shall be within accessible reach ranges. 42 inches AFF.

N R H Flooring

M	M	M	Provide sheet goods flooring (no carpet) in wheelchair accessible student rooms.
---	---	---	--

Accessible Toilets / Ambulatory Stalls – Additional Information:

1. Accessible toilet accessories installation heights, raised toilet height, interior door pulls and coat hooks are also required at all ambulatory stalls.
2. Locate centerline of toilet 16" to 18" from side wall.
3. Toilet flush control on open side of stall. Toilet height seat 17-19" to top of seat.
4. Outward swinging stall doors require two additional pulls (mounted horizontally) on the interior side of door at 36" AFF and 8 inches away from the edge of the door for symmetrical placement.
5. Install one coat hook on inside of stall door at 42" AFF.
6. TP dispenser (OFCI): surface mounted compact side by side double roll type, 10W x 6D x 7H. Install dispenser 7" from the front edge of bowl to the centerline of dispenser. Keep two inches clear space below the grab bar to the top of dispenser.
7. Paper towel dispensers (OFCI): install with operable mechanism/paddle at 42" AFF max. Dispensers may not overlap required clear floor space at sinks or create a non-cane detectable protrusion along the path of travel.
8. Soap dispensers (OFCI): install with operable mechanism/paddle at 42" AFF max/or align with the top of back-splash at vanities or with the sink splash/bottom of mirror at wall hung sinks. Provide min. (1) dispenser on wall where there is a side wall adjacent to sink. Locate the dispenser **above the counter area** with operable mechanism at 42" max. above the finished floor and at 6 inches away from the front edge of counter.
9. Sanitary napkin disposal (CFCI): a surface mounted sanitary napkin disposal is required in women's stalls and in all accessible single occupant restrooms. Install towards the back of stall next to TP dispenser. Keep 4 inches clear space below the grab bar to the top of disposal.
10. Full length framed mirror (CFCI): required in all accessible single occupant and multi-stall restrooms. Consider best wall location and to avoid sight lines into the room.
11. Trash receptacles (OFOI): Plan receptacle locations during design. Do not locate within the maneuverable clearance areas at doors. Maintain accessible clear floor space requirements.
12. Toilet seat cover dispensers (OFCI): surface mounted. Locate on the toilet wall, 2 inches below the grab bar with the outside edge of the dispenser aligned with the end of the grab bar.
13. Baby changing stations (CFCI): Project specific; confirm with PD&C PM - surface mounted, 34" AFF at open/lowered position. In the closed position, the station cannot overlap required floor spaces at fixtures or maneuvering clearances. Baby changing stations are not permitted inside accessible stalls but can be located in single toilet rooms if the maneuvering clearance space is maintained.
14. Consult with DRC on any additional Fixed restroom accessories (ie; shelves, storage, tables, benches, wall hooks, etc.)

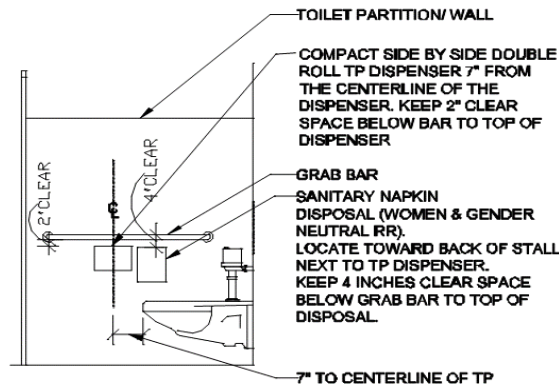

ACCESSIBLE TOILET SIDE WALL

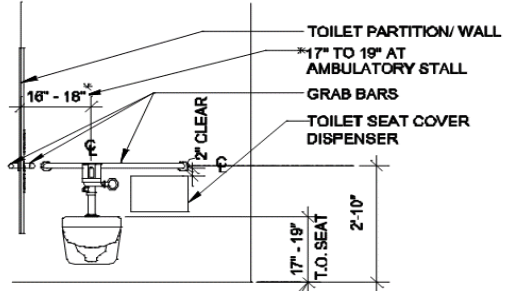

ACCESSIBLE TOILET BACK WALL

59" min
(greater than 65" if no toe clearance at front partition)

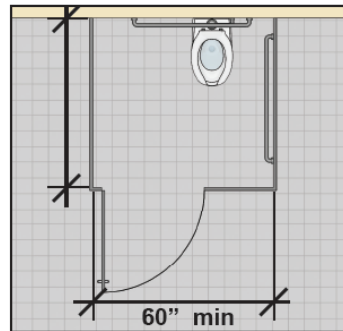

(greater than 66" if no toe clearance at a side partition)

RESTROOM STALL WITH PRIVACY PARTITION

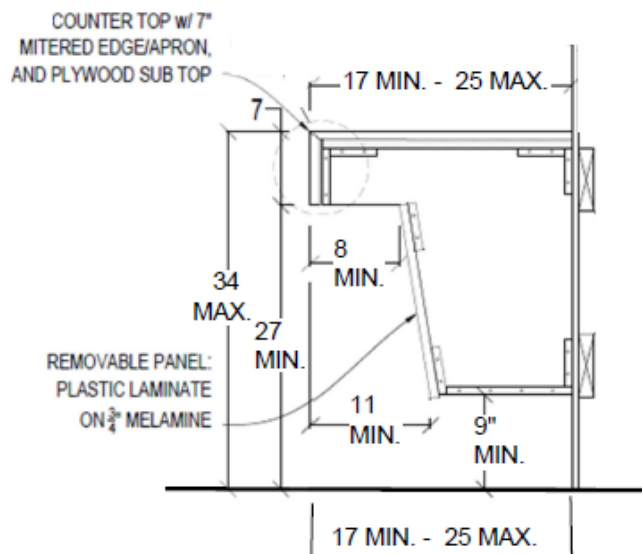

SECTION @ ADA SINK

ANGLED ACCESS PANEL SHROUD (AT SINK) DIAGRAM

Project Type Key
N = New Construction
R = Renovation
H = Historic Renovation
24 Pages

Applicability Key
M = Mandatory
P = Preferred

TYPICAL ADO LOCATIONS

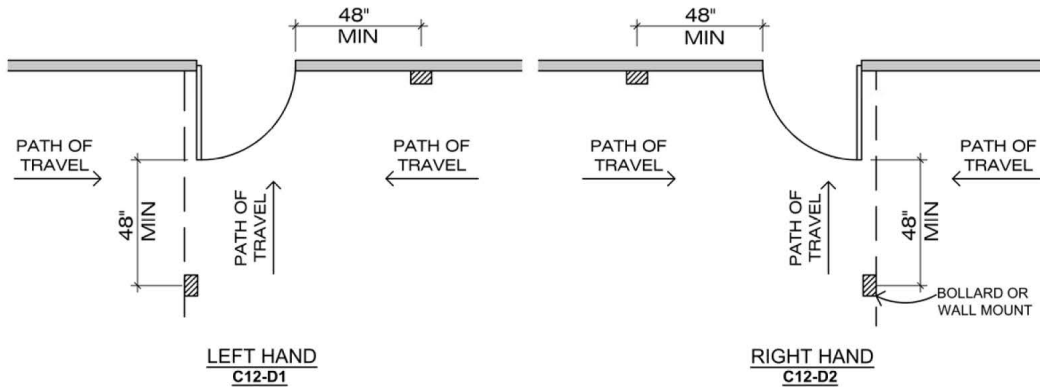

SINGLE DOOR WITH ADO

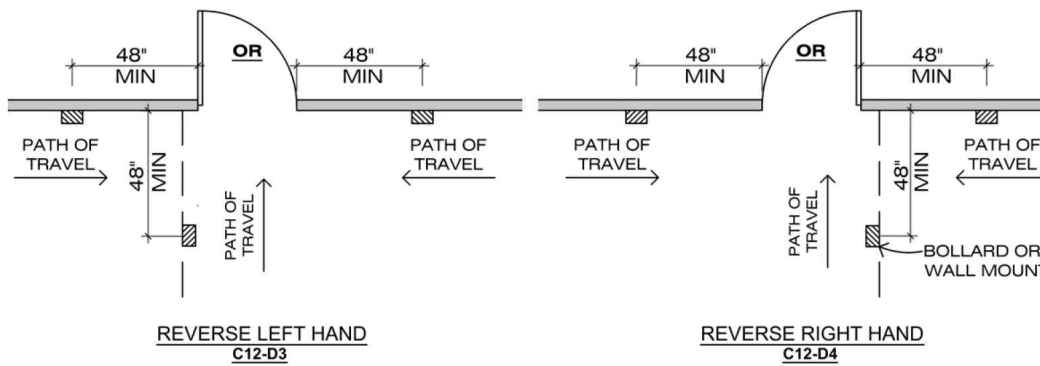

SINGLE DOOR WITH ADO

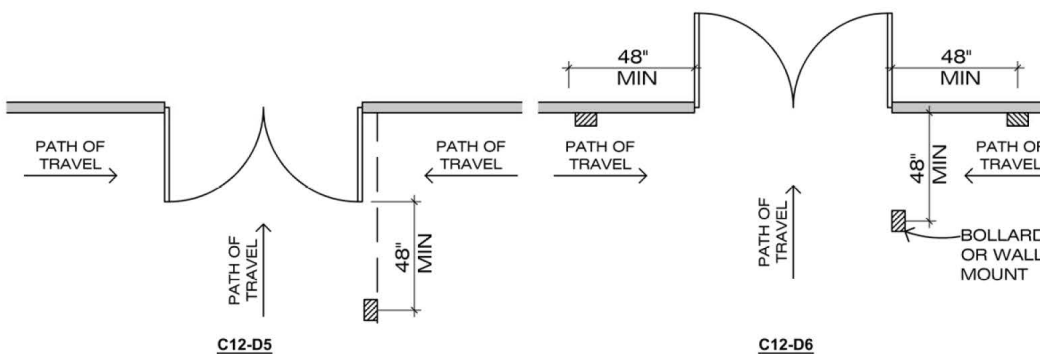

DOUBLE DOOR WITH ADO

Project Type Key
N = New Construction
R = Renovation
H = Historic Renovation
24 Pages

Applicability Key
M = Mandatory
P = Preferred

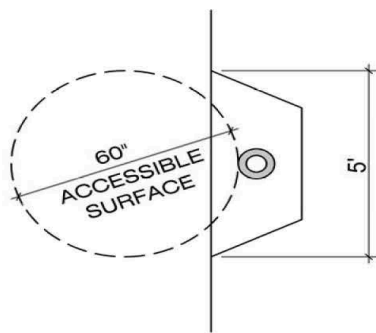

PLAN
C12-D7

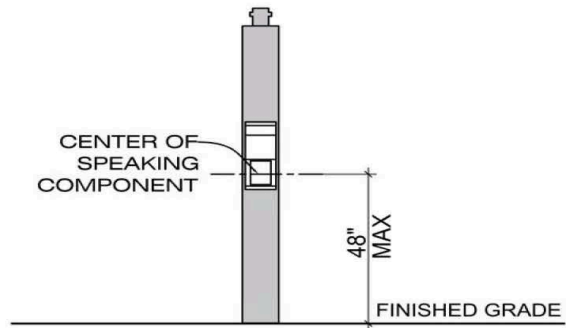

ELEVATION
C12-D8

BLUE LIGHT PHONE PEDESTAL

STANDARD REGULATORY SIGN
REFLECTIVE 0.80 ALUM. WITH
BLUE LETTERS ON WHITE
REFLECTIVE BACKGROUND

SIGNS SHALL BE PROPERLY
CENTERED WITHIN THE PARKING
SPACE

THE SIGN FACE SHOULD BE
LOCATED NO FARTHER THAN 10
FEET FROM THE FRONT OF EACH
PARKING SPACE

CONCRETE BASE FOUNDATIONS
SHALL BE CLASS 'C' CONCRETE
PER MAG SECTION 505 AND 725

THE BOTTOM OF THE SIGN SHALL
BE 60" (MIN) ABOVE FINISH GRADE.

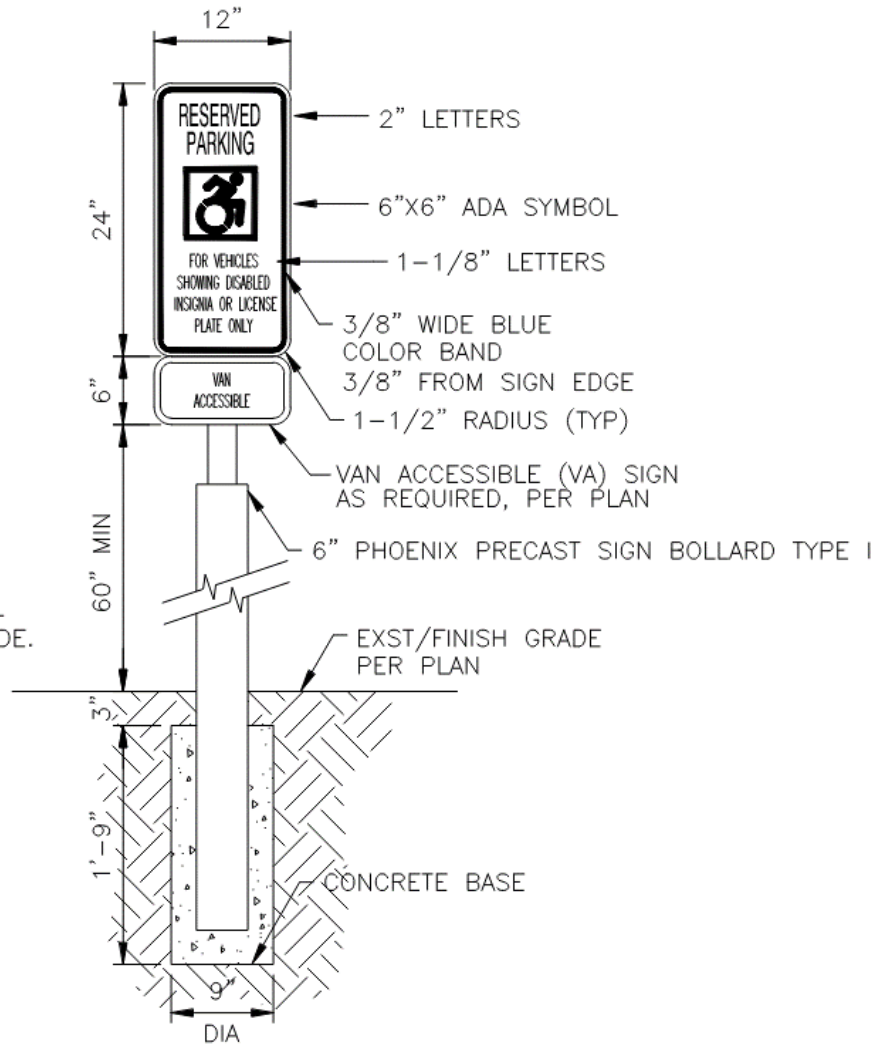

3 ADA PARKING SIGN & POST
NO SCALE

End of TAB C-12

Project Type Key
N = New Construction
R = Renovation
H = Historic Renovation
24 Pages

Applicability Key
M = Mandatory
P = Preferred

TAB C12-24

12/22