

TAB C-6

KEYLESS ACCESS AND SECURITY SYSTEM GUIDELINE

The University of Arizona has implemented a Keyless Access and Security System program to provide a cost effective, efficient, and maintainable means of providing and managing access into campus buildings for the university community, contractors and visitors. The focus of the system is to address issues of loss prevention, personal safety, and convenience through the use of this standardized technology. The system utilizes the University's Cat Card as the "key" since it is universally deployed to all campus constituencies.

The principle focus of the program addresses **building perimeter access points**. Most University facilities are unlocked during normal (and sometimes extended) business hours, during which time keys are not required to enter the building. However, when the buildings are supposed to be closed and locked, it is the program's intent to provide entry through the use of the University of Arizona Cat Card rather than with the use of a physical key.

Effective physical and electronic security is essential in providing security, access and protection to University students, personnel and assets and to mitigate threats or hazards, either natural or human-made.

The objective of the program is to provide increased security and public safety by deploying electronic access controls, door status monitoring, security systems and rekeying the perimeter access points of all major University buildings. This protocol will also be applied to new building projects, remodeling projects or additions to existing buildings.

The Keyless Access Program is intended to minimize the need for the traditional hard keys related to perimeter access to buildings. It is the intent to provide Keyless Access and Security on each side of the building to provide access to user, emergency personnel, and maintenance staff as well as facilitate future needs of the building. As the program has developed it has been determined that the use and issuance of necessary hard keys and the related hardware needed for these various doors must be addressed and clearly defined.

After hours building access will be granted by presenting a valid UA Cat Card and PIN, creating an audit trail. Building entrance doors will be rekeyed off building masters reducing the liability of lost or stolen keys. Emergency override keys will only be issued to emergency responders. The locking and unlocking of designated entry doors will be accomplished electronically, according to established schedules.

This program also integrates the room and course scheduling protocol into its operation.

When completed, this program also facilitates the ability of UAPD and /or FM Administration to remotely lock the perimeter doors of a specific building, a group of buildings, or the entire campus based on the demands of any critical situation that may occur.

Because this functionality is directly related to the locking hardware utilized on the various door configurations it will be necessary to refer to an enhanced Division 8- Doors and Windows of the DSS to clearly identify the correct door hardware, keys and keyways necessary to provide the correct functionality for each designated door.

Depending on building and layout, access points will operate in the following manner:

- Designated perimeter doors will be electrically locked and unlocked according to electronic schedule, but capable of authorized Cat Card Reader/ PIN entry after hours or on weekends.
- Secondary perimeter doors will be electrically locked and unlocked according to electronic schedule but without a Cat Card reader.
- Egress only doors will remain locked at all times.
- All perimeter doors will be equipped with door status contacts and have dog down devices removed after rekeying. This is required to provide remote perimeter lockdown capability in a threat situation.
- Designated doors will also be equipped with audible devices to sound when doors are opened during an unauthorized time.

- All roof access points and tunnel entries will be protected with a contact or motion detector based on field conditions.

REFER TO ATTACHMENT A-1 and A-2 for a door matrix to clarify the various components needed to configure doors and wiring to comply with the intent of the DSS

In order to equip new university building with this system, project consultants will need to provide a design and produce construction documents that have the following accommodations for a keyless access and security system:

- **RISER** - A riser for the building's Keyless Access/Security System. This riser is required to be stacked vertically within a building to permit the Keyless Access/Security System to be wired from floor to floor. Each building usually has a BET/MDF room and several IDF rooms located throughout the building, each of these rooms will be equipped with access control. (REFER TO ATTACHMENT B)
- **HEAD END EQUIPMENT** - Space and some utilities for the Keyless Access/Security System head end equipment directly adjacent to the riser. This particular equipment exists on only one floor of the building. This equipment also needs to be provided with two electrical 120VAC circuits consisting of one hard wired connection and one duplex outlet and two telecommunications data jacks. (REFER TO ATTACHMENT C-1 and C-2)
- **FIELD DOOR CONTROLLER PANELS** - Space and power for Keyless Access field door controller panels at various locations throughout the building as determined by the keyless access system design. Each panel requires a single hard wired 120VAC power circuit. This equipment is usually located in the various MDF and IDF rooms with the proper authorization from UITS group.
- **RACEWAYS** - Conduit and junction boxes will need to be provided for routing certain portions of the Keyless Access/Security System local area network. Not all of the keyless access and security system wiring is required to be located in conduit. In very general terms, conduit is required between the equipment that is installed on walls up to accessible, above ceiling space or to the building's cable tray. The various boxes related to this system have specific height requirements and these details are shown on the drawings and on the submittal documentation.
- **DOOR HARDWARE** – Designated doors will have hardware that needs to interface and/or be controlled by the Keyless Access system. Doors that have keyless access hardware requirements may either have their hardware specified and provided under the general construction contract (for example – in the door hardware package) or have their hardware provided by Amer-X as part of the Keyless Access/Security System installation. All door hardware must have prior approval and be provided in a configuration that will support both 12 and 24 volt DC operation. Doors that have mullions must have a quick release plug associated with the electric strike.
- **DOOR FRAMES** - Doorframes - pre-prepared from the manufacturer that can easily accommodate the addition of equipment for electronic operation. These frames typically include a handy box at the top of the doorjamb and a latch strike mud pocket that is deep enough for an electronic strike. Due to the variety of door and frame configurations these items must be clearly defined prior to bidding.

Consultant shall coordinate door functions, keyless access and security provisions, door frame requirements and Tab C-12 Campus Accessibility guidelines during the early design phase of a project. Include at this time the close coordination and interface with any automatic door operators (ADO's) and the fire alarm system.

After the award of the respective sub-contracts and prior to start of door related construction a meeting will be coordinated by the General Contractor and include the General Contractor, Electrical Contractor, Hardware Supplier, UArizona Lock Shop and Amer-x to verify the coordination of the various hardware sets and the operation of each set as it interfaces with the access control system. This meeting will also include the electrical contractor to verify and agree on all conduit requirements.

All the Keyless Access/Security System wiring is low voltage; only the head end equipment and field door controller panels require 120VAC. As such, most of the wiring is not required to be in conduit. The Keyless Access/Security System is not required to be provided with emergency power; each building's system is provided with sufficient battery backup to provide at least four hours of standby operation. In the event a particular installation calls for longer standby power capability, the 120VAC power could be on an emergency circuit. The

building Keyless Access/Security System communicates with the main server through data lines and requires connection to a hard-wired network.

The following information is intended to explain the detailed requirements of each portion of the Keyless Access/Security System infrastructure and to define the items that need to be provided by the general construction contract.

RISER (Refer to Attachment B)

- A minimum 2" riser pathway for each major wing of the building. The riser must serve every occupied floor of a building.
- One 12"x12"x4" riser box at each floor (see Notes below).
- Provide enough conduit capacity to accommodate cables required for the number of readers and related equipment per floor.

Notes:

- A building may only have one riser, but larger, more complex buildings may have more than one.
- Amer-X will provide the riser boxes for each floor of the building.

HEAD END EQUIPMENT (Refer to Attachment C-1)

Security Control Panel

- One 16"x16"x4" box for security control panel (see Notes below)
- One duplex 120VAC receptacle for panel power. This receptacle is not required to be on emergency circuit. The circuit for this receptacle is not required to be dedicated.
- One data jack.

Notes:

- Installation of security system wiring and the network and phone line between control panel and voice/data jack is provided by Amer-X.
- 120VAC-16.5 VDC transformer and transformer cover for the power receptacle will be provided and installed by Amer-X.
- Amer-X receives the box for security panel from the equipment manufacturer. Amer-X will provide this box to the electrical contractor for installation during building construction.

KEYLESS PANEL AND NETWORK CONNECTION (Refer to Attachment C-2)

- One 16"x22"x6" box for keyless access panel and network connection (see Notes below)
- One hard wired 120VAC circuit. This circuit is not required to be on emergency circuit. The circuit for this receptacle is not required to be dedicated.
- Door hardware power supply
- One data jack.

Notes:

- Installation of keyless access system wiring and the network connection cord between control panel and data jack is provided by Amer-X.
- Amer-X will terminate hard wired circuits in respective panels
- Amer-X receives the box for keyless access panel from the equipment manufacturer. Amer-X will provide this box to the electrical contractor for installation during building construction.

FIELD DOOR CONTROLLER PANELS

Depending on the number and location of controlled doors, keyless access field door controller panels will need to be installed at various locations in the building. At each of these locations, the following equipment is required:

- One 16"x22"x6" box for the field door controller panel (see Notes below)
- 120VAC power hardwired into the box. This circuit is not required to be dedicated or on emergency power.

Notes:

- The panels can be installed above accessible ceilings, in equipment rooms, or other similar areas.
- The 16"x22"x6" holds the largest field controller panel. This size box may not be needed at every location, but space should be provided to accommodate the "worst case" box.
- Amer-X receives the boxes for the field controller panels from the equipment manufacturer. Amer-X will provide these boxes to the electrical contractor for installation during building construction.
- Gutter Boxes 18"x6"x6" or other approved cable management device.

RACEWAYS

All of a building's perimeter access points will need to be provided with a wiring pathway that will permit the doors to be controlled electronically. Each building perimeter access point shall be provided with the following equipment:

- Door Contacts.
- Electronic Locking (either electric strikes or latches, or electric levers or magnetic locks (only with prior approval)).
- Request to Exit Device.

In addition, certain, designated building entries (as determined by the Keyless Access/Security System design) shall be provided with the following additional keyless access equipment:

- Card reader
- PIN pad

Raceways will need to be provided from accessible, above-ceiling spaces to this equipment at each door where this equipment is located. Closely coordinate all equipment locations and function with accessibility guidelines noted in Tab C-12 and any automatic door operators that may be required. In many cases a raceway will be provided from door equipment to the nearest building cable tray.

Notes:

- If magnetic locks are used on a door, a keyed bypass switch will be required. This is an additional piece of equipment that will also require conduit to the accessible, above-ceiling space. Magnetic locks also require a designated push to exit device and must be interconnected with the building fire alarm.
- If electrified levers are used this will require that the door hardware contractor provide devices to transition the power from the frame side to the door. The hinge wiring must be sized to handle the power requirement of the lever
- For storefront-type entries, the Keyless Access/Security System wiring can be routed through the storefront mullions. This is a field installation coordination issue that Amer-X addresses with the storefront installers during construction.
- For some glass entries, a post or bollard pedestal will be required to mount some of the keyless access equipment (card reader, PIN pads). This type of installation requires greater consideration during the project's design phase. SEE ATTACHMENT J for standard bollard pedestal detail that can be provided by Amer-X. Bollard pedestal is intended to also contain an ADO access button if required.

DOOR HARDWARE

Electronic locking requires special hardware for the doors designated to be controlled by the Keyless Access/Security System. In general terms, there are four types of electronic locking hardware: electric strikes, electric lever, electrified exit device, and magnet locks. Until the building's design reaches a point where the door types are well defined, it cannot be determined which type of electronic locking hardware will be used. However, the following should be considered:

- Magnetic locks are generally not used on UArizona projects. They should only be used when the other alternatives are not feasible (i.e. double doors that require panic hardware and cannot have a mullion).
- Electric strikes can be installed in almost all doorframes or mullions and are the most economical way to electronically lock a door.
- Electric levers and electrified exit devices are typically used where doors are required to remain

- positively latched (i.e. fire doors) in the event of a Keyless Access/Security System failure.
- QEL electrified exit devices will be used where required by code and in academic areas where necessary to limit noise from the respective electric locking mechanisms.
- Based on code requirements it may be necessary to provide fail safe or fail secure electrified locking devices.
- Electric strikes maybe more noisy than electric latching hardware and despite their higher cost the latter maybe preferred in quiet areas, i.e., classrooms, seminar spaces, study areas, etc.,
- There may be some need for the electric strike to be located in the header. This will require prior approval and special care with the installation.
- Electrified locking devices must be specified to include connectors and related cables to interface locks with the keyless access system.

DOOR FRAMES

Installation of electronic locking on doors is facilitated by having doorframes pre-prepared from the manufacturer for electronic hardware and controls. This entails the following

- A handy box provided at the top of the door frame, located 6 inches off the latch side of the frame.

ACCESS/SECURITY SYSTEM INSTALLATION

As the University's sole source, keyless access and security systems vendor, Amer-X performs the following installation tasks associated with the keyless access and security system:

- Installation of head end and field panels in boxes installed by the electrical contractor.
- Installation of 24VDC transformers and transformer covers on duplex receptacles installed by the electrical contractor.
- Connection of power source to panels.
- Connection of phone/data lines to jacks installed by the electrical contractor.
- Coordination with construction trades, such as window and door installers, to facilitate installation of peripheral devices.
- Installation of peripheral devices (door contacts, card readers, PIN pads, ADO buttons, electric strikes, etc.)
- Installation of the low voltage Keyless Access/Security System wiring - both in conduits provided by electrical contractor (in walls and vertically through the building) and the data loop local area network wiring between panels and devices (routed similar to telecommunication lines through above ceiling spaces).

DESIGN PHASE INVOLVEMENT

Please refer to the following process descriptions for how Amer-X should be involved in the design process.

DESIGN PHASE INVOLVEMENT, PROCESS AND FLOW CHART

Schematic Design

- Consultant, User group, UArizona Lock Shop, and Amer-X meet.
- Introduction of keyless access/security system.
- Review building layout, functions, different building constituencies, and expected building operation. See Note (1) below.

Design Development

- Amer-X develops preliminary system design and budget. Submits copy to Project Coordinator, Consultant, and User group.
- This document will show the various doors we plan to equip with card access and security. Each door will be identified by room number and show the various devices needed at each door. The size and scope of this safety and security program requires that the required supporting drawing and specification documentation information be part of the bid documents to ensure that the infrastructure is provided and that if changes are

needed the proper audit trails can be followed.

- Refer to Attachment D for the symbol list.
- Refer to Attachment E-1 and E-2 for reference on floor plan.
- Consultant, User group, UArizona Lock Shop and Amer-X meet. Review preliminary design with user and consultant. Make modifications/deletions/additions as determined by refined understanding of building operations and close coordination with accessibility guidelines contained in Tab C-12.
- Amer-X develops final system design and budget. Submit copy to Project Coordinator, Consultant, and User group. Provides standard door details, riser diagram, door hardware requirements to consultants.

Construction Documents

- Amer-X verifies coordination of consultant documentation with final system design.
- The architectural drawing will show a card reader symbol at each door that will be equipped with card access. The symbol will indicate the location of the reader and any related components as it relates to the door. Any door requiring pedestal will also show this location.
- Refer to Attachment F-1, F-2 and I for reference.
- The Technology and Special Systems drawings will indicate the various symbols at illustrate the devices at each door that will be equipped with card access or security. Refer to Attachment D for the symbol list.
- Refer to Attachment G for reference.
- The Door Hardware Index will list all doors that require electrical components.
- A keyless access and security door list with all the doors effected by these systems and their related peripheral devices.
- Refer to Attachment H for reference.

Construction Phase

- Electrical Contractor installs pathways (riser and door conduit) according to specifications and drawings.
- Door contractor preps doors and jambs for equipment, according to specifications and installs door hardware.
- University establishes purchase order with Amer-X for system installation.
- Amer-X coordinates field device installations with affected contractors.
- Once the construction phase of the project is completed the systems will be commissioned and become operational under the University of Arizona keyless access and security policy and procedures.

Schematic Design Note (1):

Amer-X meets with consultants and user group(s) after schematic design to introduce the keyless access/security system program, and describe the system's capabilities and options. This is where the dialog on how the users expect the building to operate from an access point of view begins. A review of the functions that take place in the building, the different user groups/constituencies, and any special concerns about asset protection, special activities (cash handling, pharmaceutical storage, etc.) and access management should also take place at this time.

User groups will be asked to think about how they need and/or want the building to be accessed.

During normal business hours.

After normal business hours.

For special events.

User Groups will also be asked to think about who they need and/or want to be able to access the building when the building is:

Normally open.

Normally closed.

University of Arizona										
Building KAS/SEC Door Types Matrix										
Door		Pin Pad		Request to	Auto Door					
Type	Description	Proximity Reader	Reader Only	Exit (REX)	Operator (ADO)	Door Contact	Electrified Hardware	Siren	Motion Detector	Output Trigger
1	Pin Pad/Reader Access Door with ADO	Yes	No	Yes	Yes	Yes	Yes	Yes	No	No
2	Pin Pad/Reader Access Door <u>without</u> ADO	Yes	No	Yes	No	Yes	Yes	Yes	No	No
3	Door Schedule - Electrified Hardware	No	No	Yes	No	Yes	Yes	Yes	No	No
4	Monitor Door Status with Exit Shunt	No	No	Yes	No	Yes	No	Yes	No	No
5	Monitor Door Status Only	No	No	No	No	Yes	No	Yes	No	No
6	Reader for Type #3 Lock Control	No	Yes	No	No	No	No	No	No	No
7	Roof Access, Hatch, Tunnel Access, Gate	No	No	No	No	Yes	No	Yes	No	No
8	Area Monitoring	No	No	No	No	No	No	No	Yes	No
9	Elevator-Restricted Floor Access	No	Yes	No	No	No	No	No	No	Yes
10	Elevator-Call Button Activation	No	Yes	No	No	No	No	No	No	Yes

ATTACHMENT A-1

University of Arizona									
Building KAS/SEC Wiring Matrix									
All Wire is Plenum Rated									
Door		Pin Pad		Request to	Auto Door				
Type	Description	Contactless	Reader	Exit	Opener	Door	Electrified	Siren	Conduit
		Reader	Only	(REX)	(ADO)	Contact	Hardware		Requirements
1	Pin Pad/Reader Access Door with ADO	18/6	0	22/4	22/4	18/2	18/4	18/4	3/4"
2	Pin Pad/Reader Access Door without ADO	18/6	0	22/4	0	18/2	18/4	18/4	3/4"
3	Electrified Hardware with Exit Only	0	0	22/4	0	18/2	18/4	18/4	3/4"
4	Exit Only	0	0	22/4	0	18/2	0	18/4	3/4"
5	Monitor Door Status Only	0	0	0	0	18/2	0	18/4	3/4"
6	Reader for Type #3 Lock Control	0	18/6	0	0	0	0	0	3/4"
7	Roof Hatch, Gate Tunnel Access	0	0	0	0	22/4	0	18/4	3/4"
8	General Monitoring Device, Temp, Motion	0	0	0	0	22/4	0	0	3/4"
9	Elevator-Restricted Floor Access	0	0	0	0	018/2	18/4	18/4	3/4"
10	Elevator Call Button Activation	0	18/6	0	0	0	18/4	0	3/4"

ATTACHMENT A-2

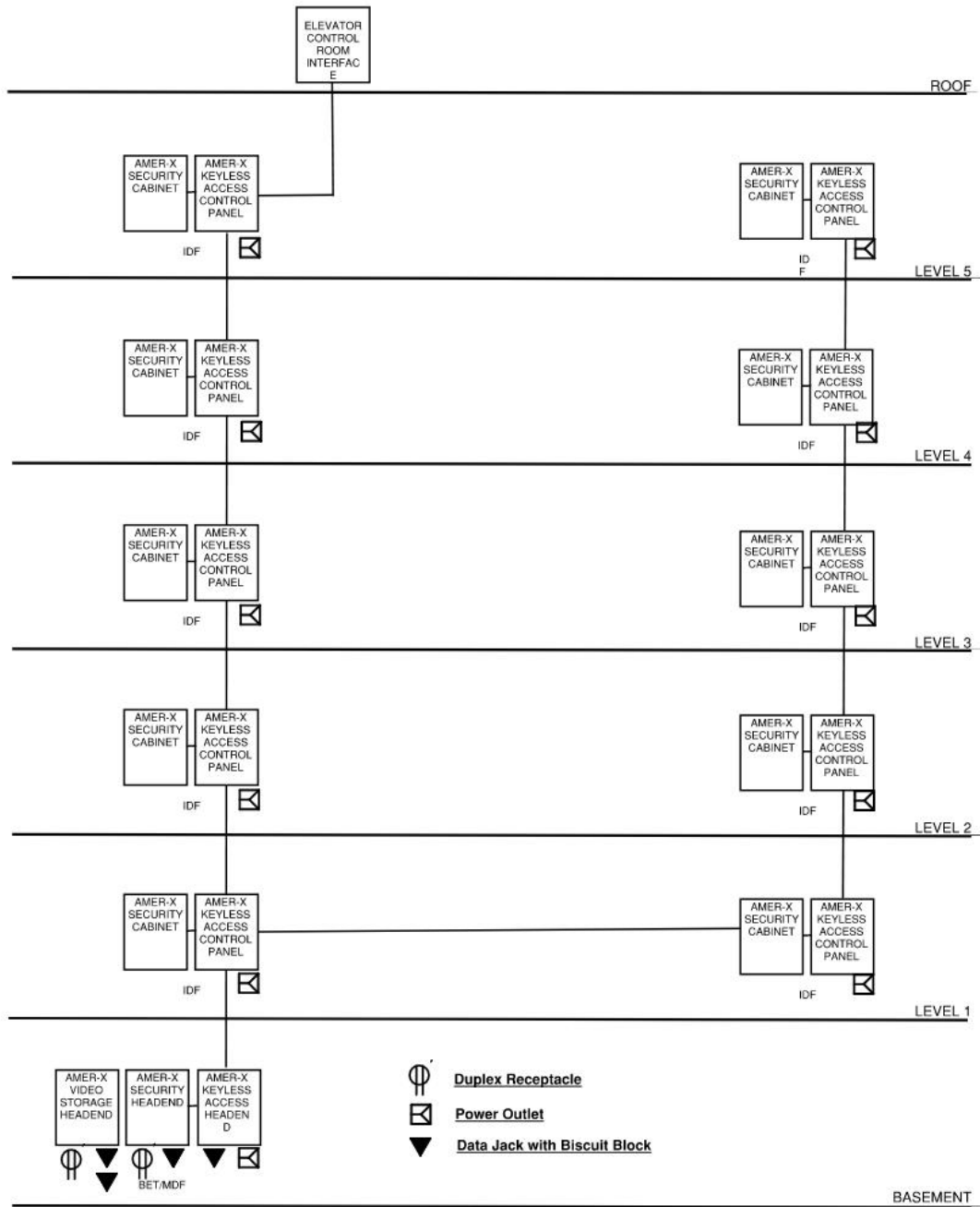

**UARIZONA KEYLESS ACCESS AND SECURITY SYSTEMS
 RISER DIAGRAM**



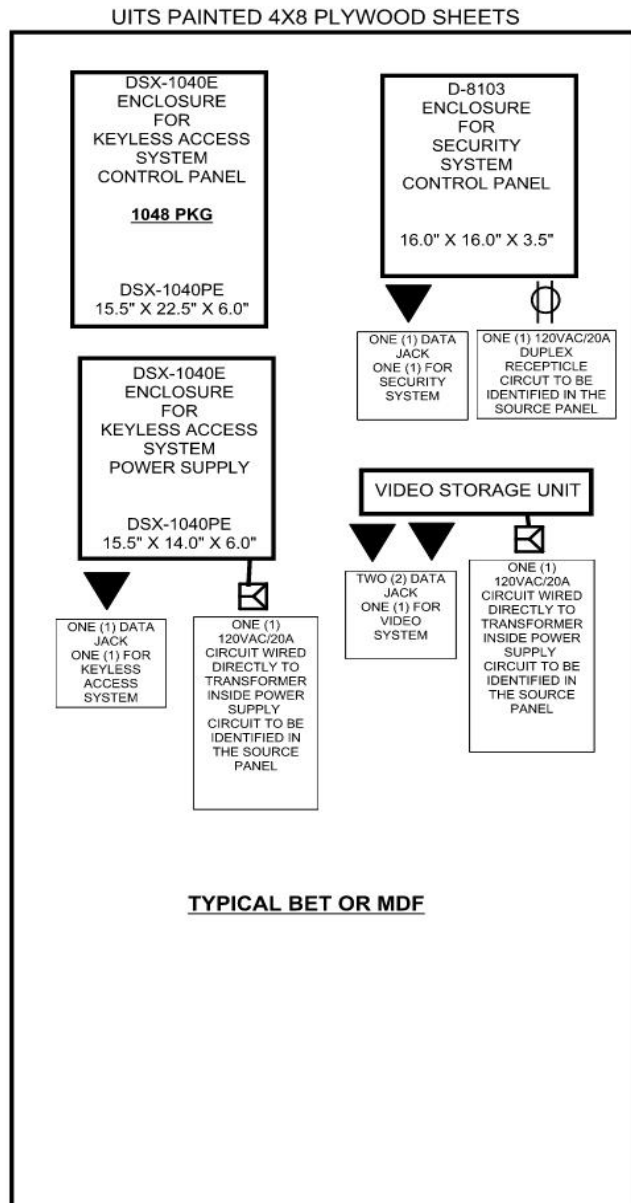



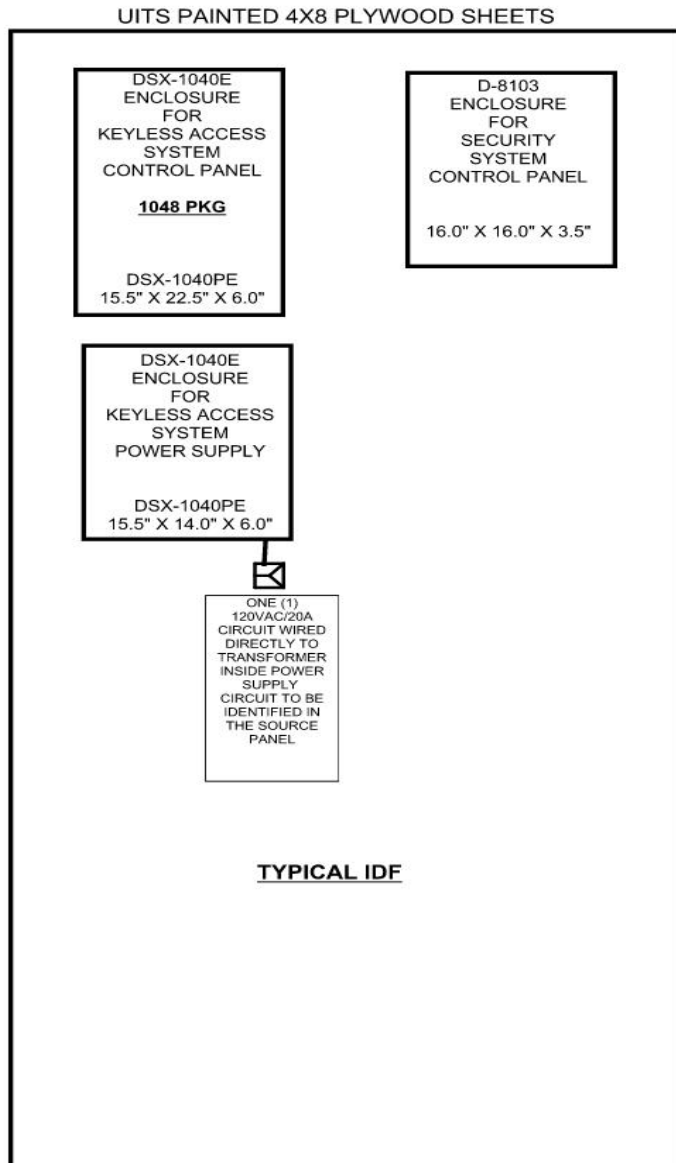













ATTACHMENT B



ATTACHMENT C-1



ATTACHMENT C-2

<u>UARIZONA SECURITY SYSTEMS</u> <u>SYMBOL LIST</u>	
KEYLESS ACCESS SYSTEM	
 KAS	KEYLESS ACCESS SYSTEM CONTROL PANELS
 CR	CARD READER
 CRP	CARD READER WITH PINPAD
 ADO	AUTOMATIC DOOR OPENER INTERFACE
 PED	UARIZONA STANDARD PEDESTAL
 DC	DOOR POSITION SWITCH
 AD	AUDIABLE DEVICE
 EL	ELECTRIC LEVER LOCK (EPT OR HINGE)
 ES	ELECTRIC STRIKE LOCK
 EED	ELECTRIC EXIT DEVICE LOCK (EPT OR HINGE)
 EPT	ELECTRIC POWER TRANSFER
 WH	WIRED HINGE
 REX	REQUEST TO EXIT DEVICE
 ELI	ELEVATOR INTERFACE
SECURITY SYSTEM	
 SEC	SECURITY CONTROL PANEL
 KP	KEYPAD
 DC	DOOR POSITION SWITCH
 MD	MOTION DETECTOR
 DB	DURESS BUTTON
 WR	WIRELESS REPEATER

ATTACHMENT D

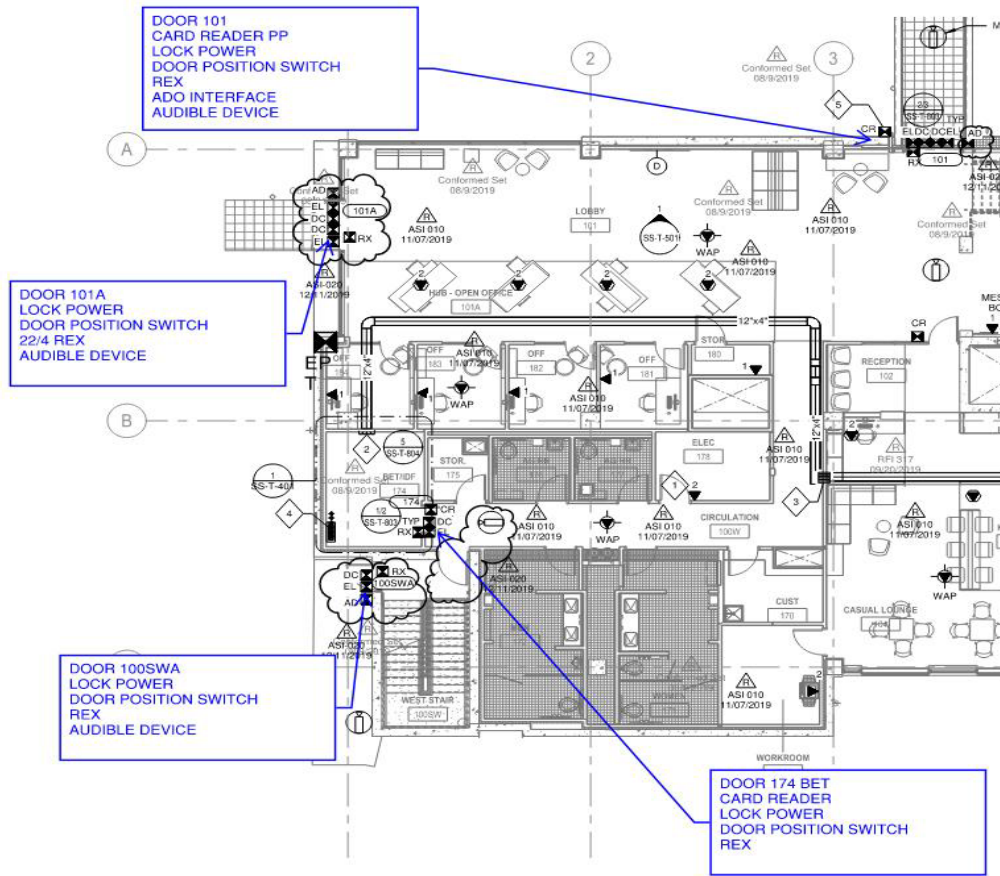

1 TECHNOLOGY FLOOR PLAN - LEVEL 1
 1/8" = 1'-0"

ATTACHMENT E-1

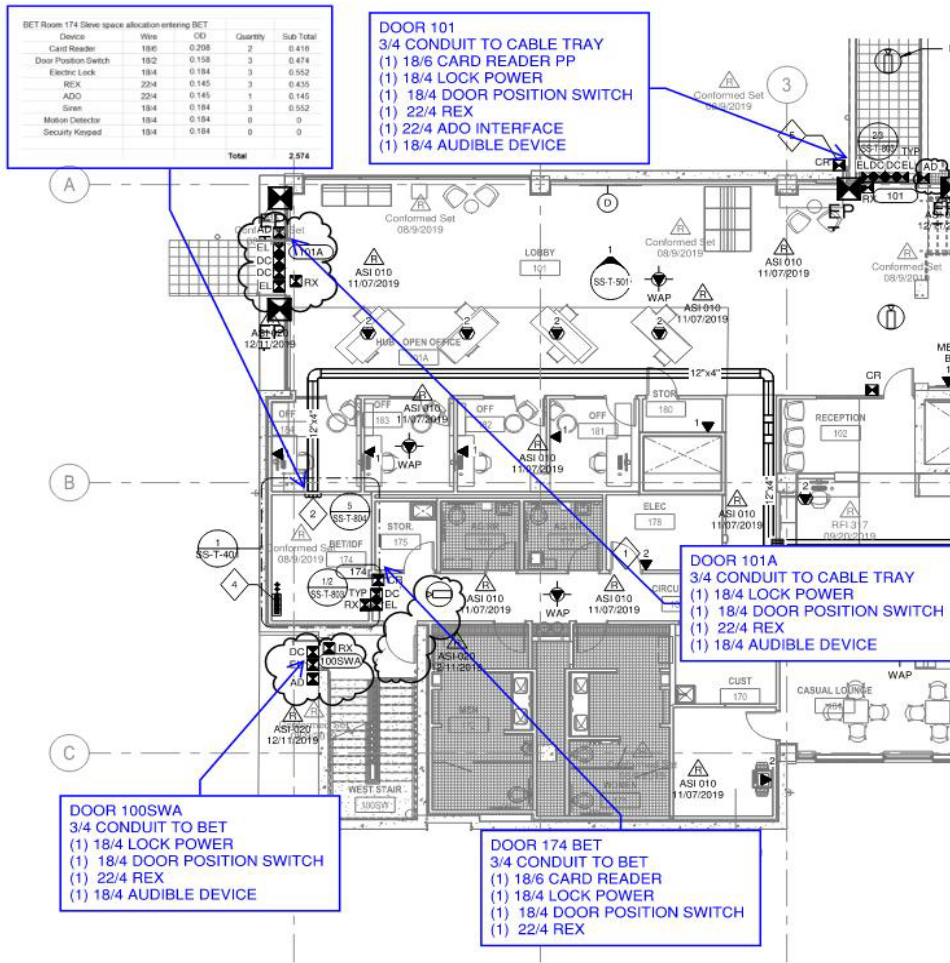

1 TECHNOLOGY FLOOR PLAN - LEVEL 1
1/8" = 1'-0"

Device	Wire	OD	Quantity	Sub Total
Card Reader	18/6	0.208	7	1.456
Door Position Switch	18/2	0.158	6	0.948
Electric Lock	18/4	0.184	5	0.92
REX	22/4	0.145	5	0.725
ADO	22/4	0.14	0	0
Siren	18/4	0.184	1	0.184
Motion Detector	18/4	0.184	6	1.104
Security Keypad	18/4	0.184	2	0.368
Total				5.705

ATTACHMENT E-2

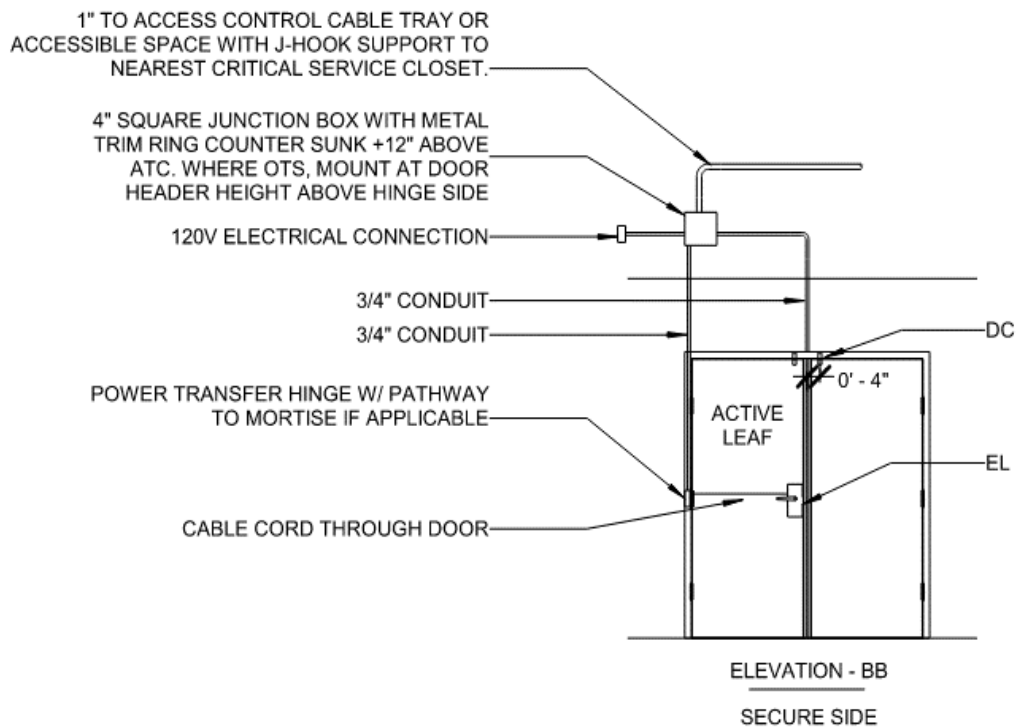
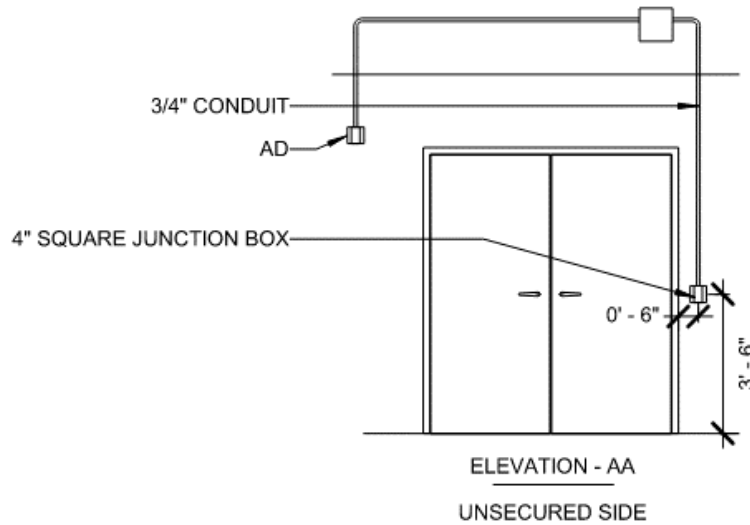

NOTE:
THIS DETAIL IS PROVIDED FOR REFERENCE ONLY - ARCHITECTURAL INDICATES CABLE PATHWAYS FOR DOOR HARDWARE AND DEVICES IF THERE ARE ANY DISCREPANCIES BETWEEN THIS AND ARCHITECTURAL, ARCHITECTURAL SHALL GOVERN.

3 **DETAIL - DOUBLE DOOR WITH ELECTRIC LOCKSET, DOOR POSITION SWITCH, CARD-IN READER, AUDIABLE DEVICE**

ATTACHMENT F-1

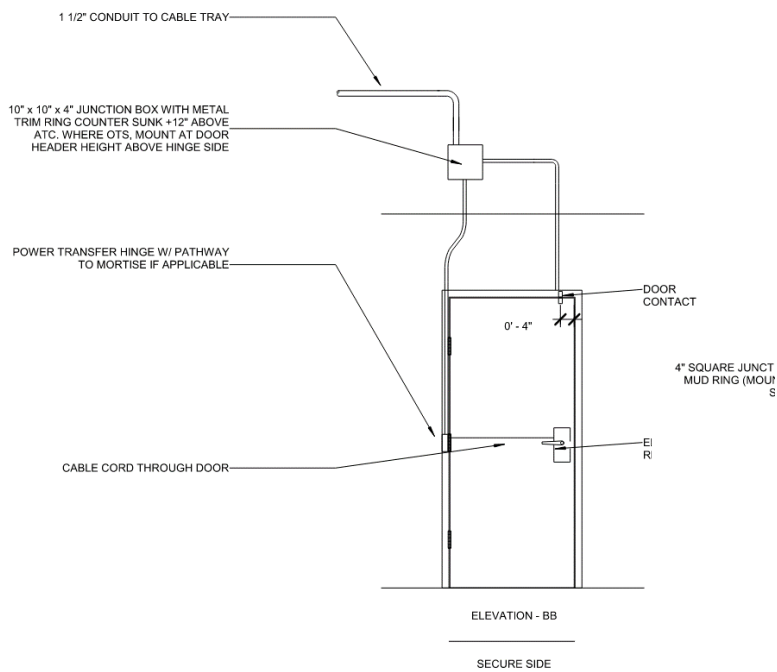
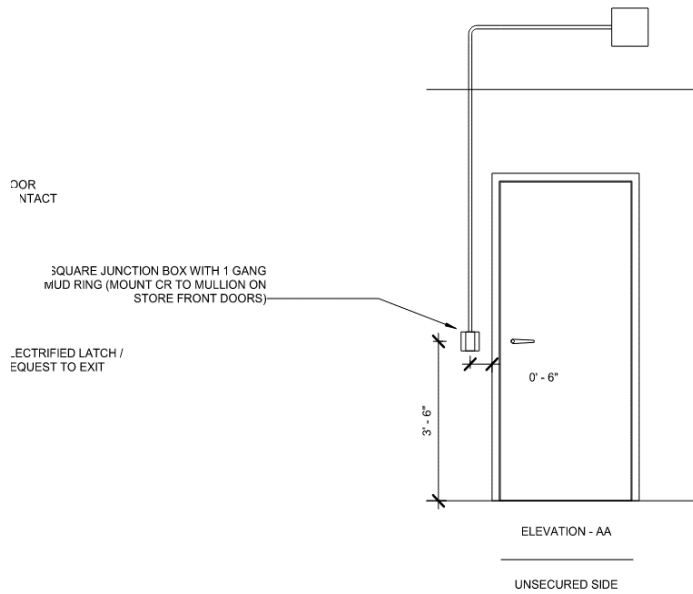

NOTE:
THIS DETAIL IS PROVIDED FOR REFERENCE ONLY - ARCHITECTURAL INDICATES CABLE PATHWAYS FOR DOOR HARDWARE AND DEVICES IF THERE ARE ANY DISCREPANCIES BETWEEN THIS AND ARCHITECTURAL, ARCHITECTURAL SHALL GOVERN.

DETAIL - INTERIOR - SINGLE DOOR WITH ELECTRIC LOCKSET, DOOR POSITION SWITCH, CARD-IN READER2

1

ATTACHMENT F-2

SAMPLE HARDWARE SETS

⚡ = Hardware Item Requiring Electrical Coordination

HARDWARE GROUP NO. 01

For use on Door #(s):

001E	001W	100W	200E	200W	300E
300W	400E	400W	500E	500W	600E
600W	700E	700W			

Provide each SGL door(s) with the following:

QTY		DESCRIPTION	CATALOG NUMBER		FINISH	MFR
3	EA	HINGE	5BB1HW 4.5 X 4.5 NRP	[P]	652	IVE
1	EA	ELECTRIC HINGE	5BB1HW 4.5 X 4.5 CON TW8	[P] ⚡	652	IVE
1	EA	FIRE EXIT DEV	99-L-F-E996-06-FS CON	[P]	626	VON
1	EA	PERM CORE	MEDECO BY OWNER		626	MED
1	EA	CYLINDER AS REQ	MEDECO BY OWNER		626	MED
1	EA	SURFACE CLOSER	4040XP REG TBWMS	[P]	689	LCN
1	EA	KICK PLATE	8400 10" X 2" LDW B-CS	[P]	630	IVE
1	EA	WALL STOP	WS401/402CVX	[P]	626	IVE
1	EA	DOOR SEAL	488S	[P]	BK	ZER
1	EA	WIRE HARNESS	CON-XXX AS REQ			SCH
1	EA	CARD READER	BY SEC VEND		⚡ BLK	
1	EA	DOOR CONTACT	BY SEC VEND		⚡ BLK	
1	EA	REQUEST TO EXIT	BY SEC VEND		⚡ BLK	
1	EA	POWER	BY SEC VEND		⚡ LGR	

#

HARDWARE GROUP NO. 02

For use on Door #(s):

002	002-A	012-A	014-A	018-A	022-A
024-A	026-A	038-A	044-A	046-A	050-A
052-A	056-A	202	202-C	212-A	214-A
218-A	222-A	224-A	226-A	238-A	240-A
244-A	246-A	250-A	252-A	256-A	302
302-C	312-A	314-B	318-A	322-A	324-A
326-A	338-A	340-A	344-A	346-A	350-A
352-A	356-A	402	420	420-C	

Provide each PR door(s) with the following:

QTY		DESCRIPTION	CATALOG NUMBER		FINISH	MFR
7	EA	HINGE	5BB1HW 4.5 X 4.5 NRP	[P]	652	IVE
1	EA	ELECTRIC HINGE	5BB1HW 4.5 X 4.5 CON TW8	[P] ⚡	652	IVE
2	EA	SURFACE BOLT	SB360	[P]	604	IVE
1	EA	ELECT LOCK	ND80PDEU RHO 14-049 CON	[P] ⚡	626	SCH
1	EA	PERM CORE	MEDECO BY OWNER		626	MED
1	EA	OH STOP	90S	[P]	630	GLY
1	EA	SURFACE CLOSER	4040XP HCUSH TBWMS	[P]	689	LCN
2	EA	KICK PLATE	8400 10" X 1" LDW B-CS	[P]	630	IVE
1	EA	SEAL	312A-S	[P]	A	ZER
1	EA	DOOR SEAL	488S	[P]	BK	ZER
2	EA	MORT AUTO DR BTM	360AA	[P]	AA	ZER
1	EA	ASTRAGAL	43 X 188S	[P]	STST	ZER
1	EA	FLAT PLATE	601CPA X DW X JD	[P]	A	ZER
2	EA	WIRE HARNESS	CON-XXX AS REQ			SCH
1	EA	CARD READER	BY SEC VEND		⚡ BLK	
2	EA	DOOR CONTACT	BY SEC VEND		⚡ BLK	
1	EA	REQUEST TO EXIT	BY SEC VEND		⚡ BLK	
1	EA	POWER	BY SEC VEND		⚡ LGR	

#

ATTACHMENT G

UARIZONA KEYLESS ACCESS AND SECURITY DOOR LIST

Line#	Door Number	Door Type	Number Doors	Door Swing	Hardware Set	Elec Strike	Lever	Exit Device	EPT	Trans Hinge	Card Reader	Door Pos Switch	Rex	ADO	Audible Device
1	102	ALUM	DOUBLE	N/A	AL-001	0	0	2	2	0	1	2	1	1	1
2	0179	H.M.	SINGLE	LEFT	1	1	0	0	0	0	1	1	1	0	0
3	0101A	ALUM	DOUBLE	N/A	AL-001	0	0	2	2	0	1	2	1	0	0
4	0101B	ALUM	DOUBLE	N/A	AL-001	0	0	2	2	0	1	2	1	0	0
5	0105A	ALUM	DOUBLE	N/A	AL-001	0	0	2	2	0	1	2	1	0	0
6	C101B	H.M.	DOUBLE	N/A	15	0	0	2	2	0	1	2	1	1	1
7	C101C	H.M.	DOUBLE	N/A	16	0	0	2	2	0	1	2	1	0	0
8	C101D	H.M.	DOUBLE	N/A	17	0	0	2	2	0	1	2	1	0	0
9	0104C	H.M.	DOUBLE	N/A	26	0	0	2	2	0	1	2	1	0	0
10	0104D	ALUM	DOUBLE	N/A	AL-001	0	0	2	2	0	1	2	1	1	1
11	C105A	H.M.	SINGLE	RIGHT	15	1	0	0	0	0	1	1	1	0	0
12	C105B	H.M.	SINGLE	RIGHT	16	1	0	0	0	0	1	1	1	1	1
13	C105C	H.M.	SINGLE	LEFT	17	1	0	0	0	0	1	1	1	0	0
14	C105D	H.M.	SINGLE	LEFT	26	1	0	0	0	0	1	1	1	1	1
15	C106	H.M.	SINGLE	LEFT	24	1	0	0	0	0	1	1	1	0	0
16	0111B	H.M.	SINGLE	LEFT	28	1	0	0	0	0	1	1	1	1	1
17	0112	H.M.	DOUBLE	LEFT	15	0	0	2	2	0	1	2	1	0	0
18	0122A	ALUM	SINGLE	RIGHT	AL-001	0	1	0	0	1	1	1	1	0	0
19	0122B	ALUM	SINGLE	LEFT	AL-001	0	1	0	0	1	1	1	1	0	0
20	0155C	H.M.	SINGLE	RIGHT	18	0	1	0	0	1	1	1	1	0	0
21	0181A	ALUM	SINGLE	LEFT	AL-001	0	1	0	0	1	1	1	1	0	0
22	0181B	H.M.	SINGLE	LEFT	17	0	1	0	0	1	1	1	1	0	0
23	0182A	ALUM	SINGLE	RIGHT	AL-001	0	1	0	0	1	1	1	1	0	0
24	0182B	H.M.	SINGLE	RIGHT	4	0	1	0	0	1	1	1	1	0	0
25	01S1B	ALUM	SINGLE	RIGHT	AL-001	0	1	0	0	1	1	1	1	0	0
26	01S2B	H.M.	SINGLE	RIGHT	11	0	1	0	0	1	1	1	1	0	0
27	01S3B	H.M.	SINGLE	LEFT	12	0	1	0	0	1	1	1	1	0	0
28	01S4B	H.M.	SINGLE	LEFT	13	0	1	0	0	1	1	1	1	0	0
29	01S5A	H.M.	SINGLE	LEFT	14	0	1	0	0	1	1	1	1	0	0
30	01S5B	H.M.	SINGLE	LEFT	15	0	1	0	0	1	1	1	1	0	0
					Totals	7	13	20	20	13	30	40	30	6	6
Line#	Door Number	Door Type	Number Doors	Door Swing	Hardware Set	Elec Strike	Lever	Exit Device	EPT	Trans Hinge	Card Reader	Door Pos Switch	Rex	ADO	Audible Device

ATTACHMENT H

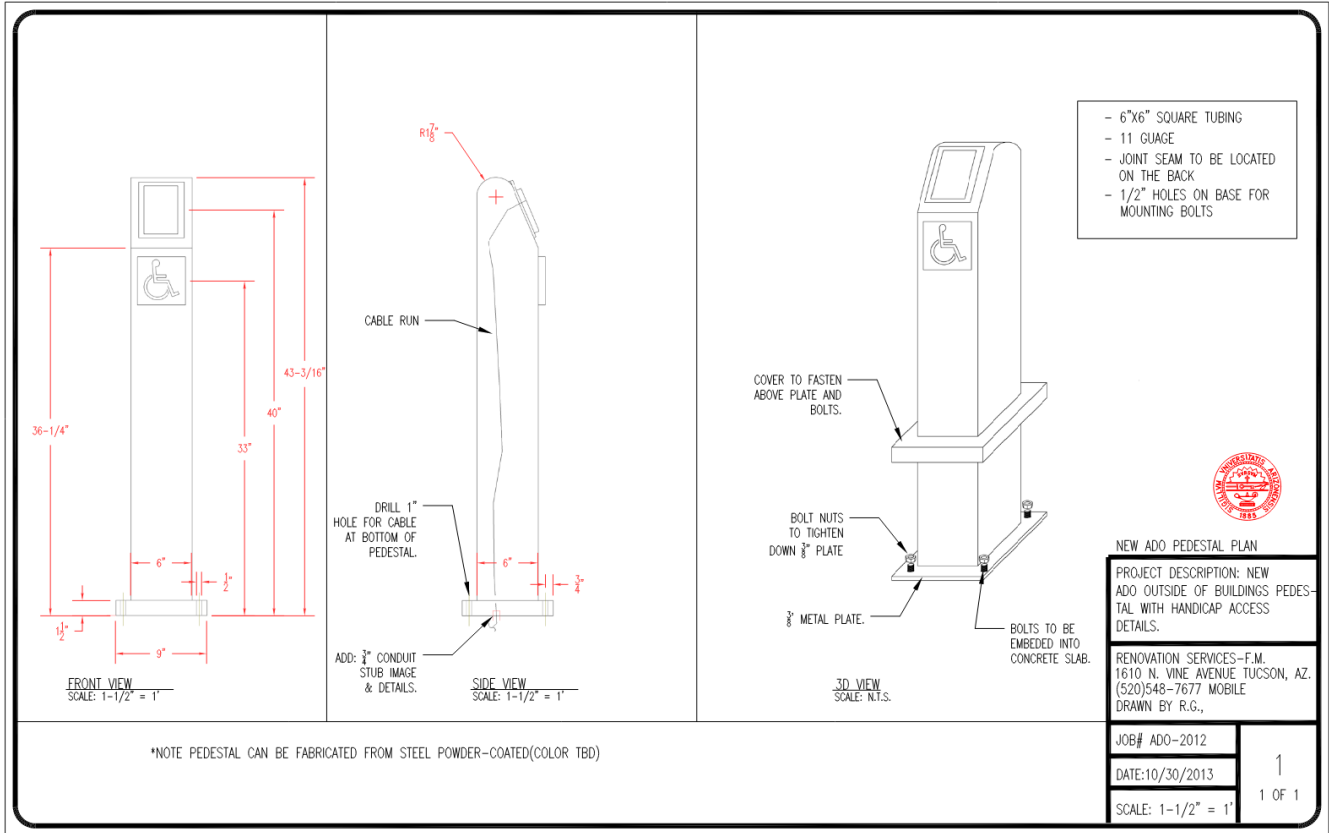

ATTACHMENT I

End of Tab C-6