

Division 15 Mechanical

Section 15970 - Control Systems

Introduction

Equipment associated with:

THE MANAGEMENT OF HEATING, VENTILATION, AND AIR CONDITIONING RELATED UTILITIES.

Part 1 – General

- The University of Arizona requires EMCS providers to design, build, configure, and implement technology using a specified architecture that meshes with University of Arizona processes and procedures, allowing for interoperability, scalability, and high performance. This document is intended to assist the EMCS provider in understanding University of Arizona Standards and Specifications in a brief, illustrated overview
- Overall Architecture
The EMCS architecture is broken up into layers:
 - Control Layer: comprised of devices that host all I/O and all control logic required to control equipment; this layer also includes protocol routers
 - Integration Layer: comprised of gateways employing drivers to integrate legacy systems
 - Enterprise Layer: comprised of data-center-based server software hosting GUI and EMCS maintenance tools
 - Historian Layer: comprised of consolidated data repository for archived data

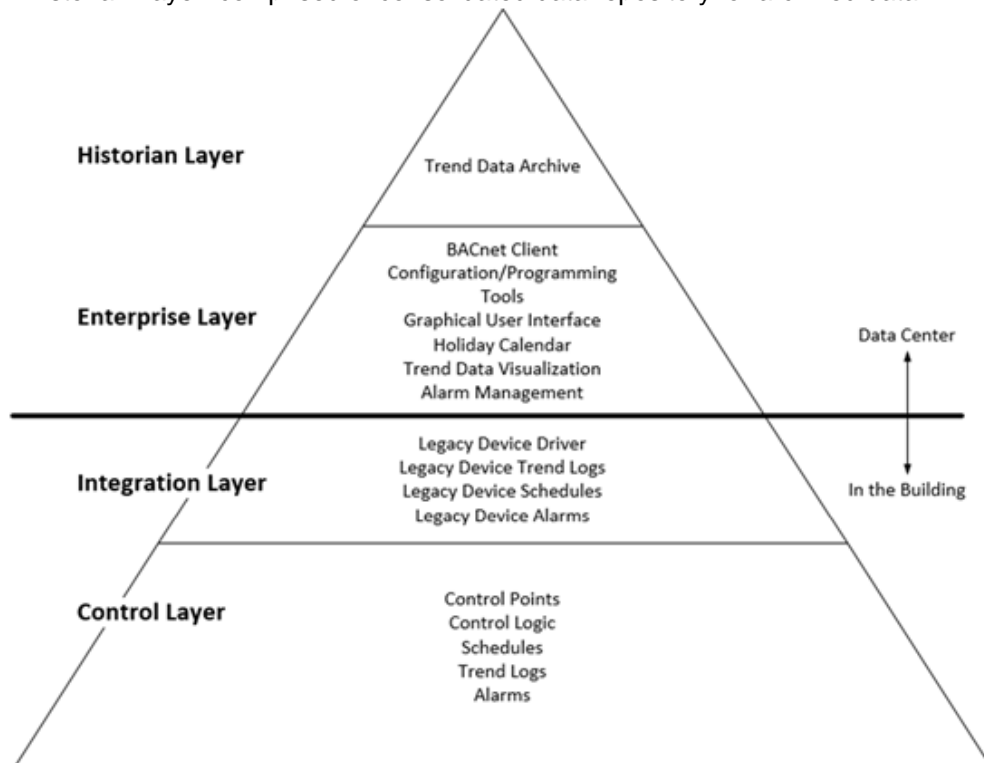

- BACnet
All new devices on the Control Layer shall be native-BACnet. This is intended to provide full interoperability on the Control Layer without the need for integration gateways or drivers. The EMCS provider is responsible for delivering and deploying BACnet devices that successfully join the BACnet internetwork without errors or communications issues. The University of Arizona manages IP and BACnet network configuration parameters:
 - IP address, subnet mask, default gateway
 - UDP port
 - BACnet Network Number
 - BACnet Device ID
 - BACnet MS/TP MAC address
 - BBMD functionality

These parameters are managed by University of Arizona, and shall not be assigned ad hoc.

- Network Architecture
The network architecture model is BACnet/IP-based for major equipment controllers, and BACnet MS/TP-based for small equipment.
- Major equipment refers to central plant equipment, multi-zone AHUs and AHUs serving terminal units, central lighting panels, etc.
Small equipment refers to FCU, VAV, CV, FTU, VRV, VV terminal units, single-zone AHUs, single-zone RTUs, VFDs, chillers, boilers, room or area lighting controllers, etc.
If you are not sure if a device should be BACnet/IP or BACnet MS/TP, check with University of Arizona
- The network strategy allows for approximately 30 devices per MS/TP network. It is preferred that MS/TP networks do not run between floors. Ideally the MS/TP network should be modeled after the equipment arrangement



Typical equipment arrangement

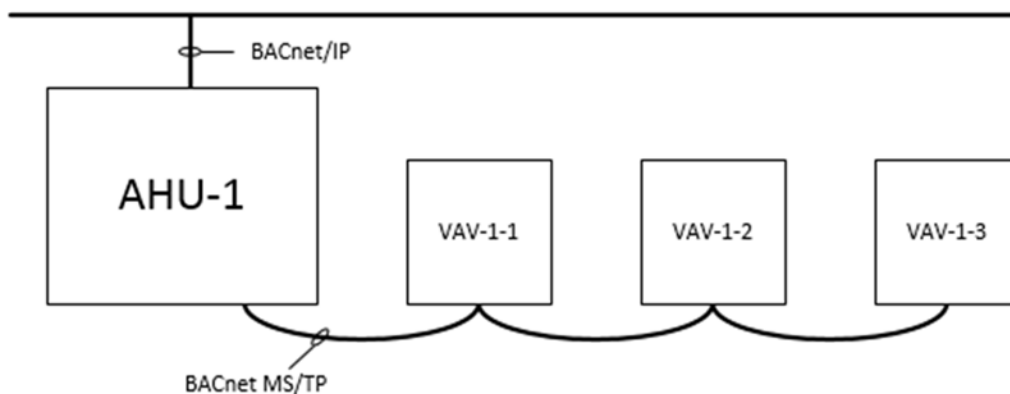

Matching network arrangement

- BACnet/IP devices shall be connected to the existing University of Arizona IP network, and *not* on an ad hoc network. BACnet/IP routers shall be located on each floor or area allowing any MS/TP devices on that floor or area to be connected. The BACnet/IP router may be a major equipment controller, such as an AHU controller. The overall network riser should resemble the figure below:

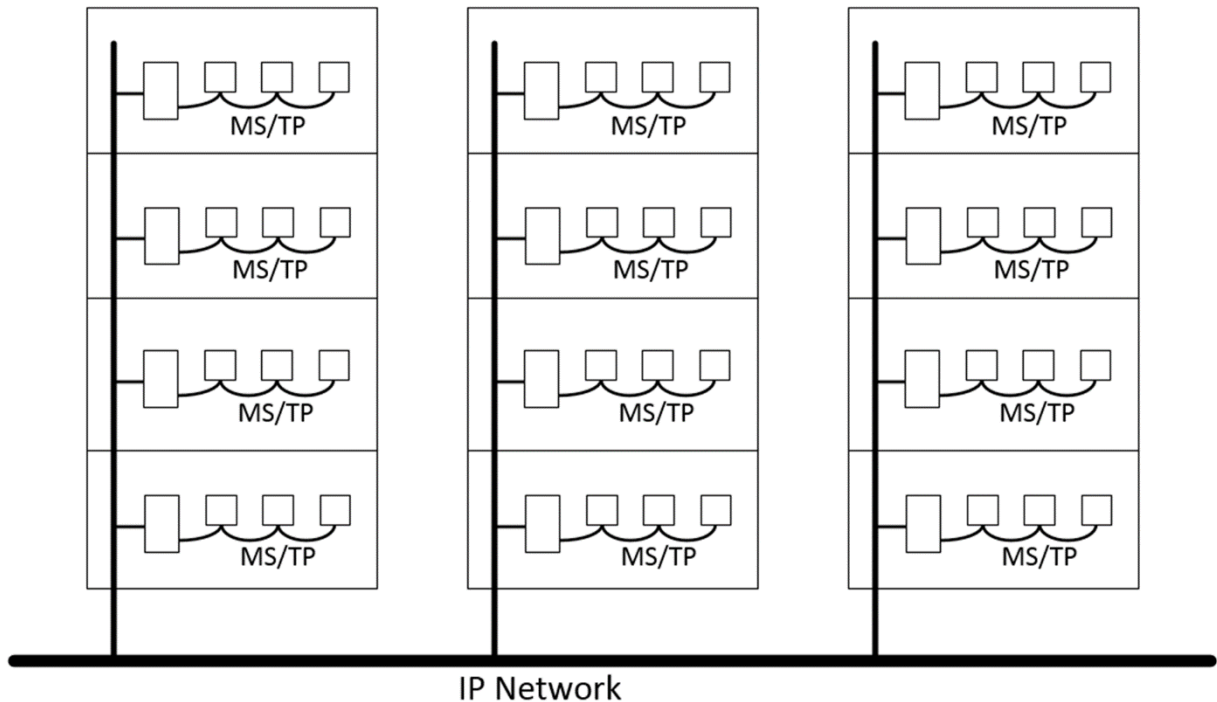

Part 2 - Products

- Any device proposed or submitted for use on University of Arizona property shall be reviewed by the University of Arizona. The EMCS provider must provide adequate information to assess the device in terms of functionality, security, applicability, and ultimate suitability for use in University of Arizona buildings/facilities. One important document is the BACnet PICS. No BACnet device will be permitted without a PICS. The other important item is BTL Certification. University of Arizona prefers devices that are BTL-certified, and requires it in the specification. However, exceptions of BTL-certification can be made at the discretion of the reviewing University of Arizona technical engineer.
- All devices shall be BACnet, including any I/O or remote I/O expansion devices

Part 3 - Execution

- See specifications in the Appendix App-15970 for more detail

End of Section 15970